

# Digital Wireless Receiver

Operating Instructions

DWR-S02DN

**DWX** **WiDIF-HP**  
DIGITAL WIRELESS  Cross Remote

# Table of Contents

<b>Features</b> .....	<b>3</b>	Display of the Power Save Setting (POWER SAVE) .....	15
<b>Parts Identification</b> .....	<b>4</b>	Display of Accumulated Battery Use Time (TIME) .....	15
<b>Preparation</b> .....	<b>5</b>	Display of the +48V Power Setting (+48V) .....	15
Attaching to a Camcorder .....	5	Cross Remote (RF REMOTE) .....	15
Using the DWA-01D/F01D Wireless Adapter .....	6	<b>Using the Cross Remote</b> .....	<b>16</b>
<b>Setting the Receiving Channel</b> .....	<b>6</b>	Pairing with a Transmitter .....	16
Selecting the Frequency Band / Group / Channel .....	6	<b>Changing the Settings on the Transmitter</b> .....	<b>17</b>
Using the Active Channel Scan Function .....	7	Group/Channel Setting (GP/CH) .....	17
Using the Clear Channel Scan Function .....	7	Frequency Band Setting (BAND) .....	17
<b>Using the Encrypted Transmission Function</b> .....	<b>8</b>	Transmission Power Setting (RF POWER) .....	17
Using Secure Key Mode (SECURE KEY) .....	8	Audio Input Level Setting (INPUT LEVEL) .....	18
Using Password Mode (PASSWORD) .....	9	Low-cut Filter Setting (LCF) .....	18
<b>Using a USB Keyboard</b> .....	<b>10</b>	Power-saving Setting (POWER SAVE) .....	18
<b>Menu Displays and Detailed Settings</b> .....	<b>10</b>	+48V Power Setting (+48V) .....	18
Menu Structure and Hierarchy .....	10	Cross Remote Setting (RF REMOTE) .....	18
Basic Menu Operations .....	11	Audio codec mode setting (CODEC MODE) .....	18
<b>UTILITY Menu</b> .....	<b>12</b>	<b>Block Diagram</b> .....	<b>19</b>
Selecting the AES/EBU Output Reference Level (AES/EBU LVL@MIC) .....	12	<b>Troubleshooting</b> .....	<b>20</b>
Selecting the Sync Signal (SYNC SOURCE) .....	12	<b>Important Notes on Operation</b> .....	<b>22</b>
Terminating the Sync Signal (WORD SYNC 75ohm) .....	12	Notes on Using the Receiver .....	22
Selecting Output 1 (ANALOG OUTPUT1) .....	12	On Cleaning .....	22
Showing the Accumulated Use Time (TIME) .....	12	Transmitter software version .....	22
Setting the Brightness of the Display (BRIGHTNESS) .....	13	Audio degradation due to weak reception .....	22
Automatic Dimming of the Display (DIMMER MODE) .....	13	<b>Specifications</b> .....	<b>23</b>
Resetting Parameters to their Factory Settings (FACTORY PRESET) .....	13	<b>Carrier Frequencies and Channel Steps</b> .....	<b>24</b>
Displaying the Software Version (VERSION) .....	13		
<b>RX (tuner) 1/2 Menu</b> .....	<b>13</b>		
Group/Channel Selection (GP/CH) .....	13		
Frequency Band Selection (BAND) .....	13		
Active Channel Scanning Function (ACT CH SCAN) .....	13		
Clear Channel Scan Function (CLR CH SCAN) .....	13		
Using the RF Squelch Function (RF SQUELCH) .....	14		
Encrypted Transmission Function (ENCRYPTION) .....	14		
Setting the Audio Codec Mode (CODEC MODE) .....	14		
Display of the Audio Signal Delay Time (SYSTEM DELAY) .....	14		
<b>TX (Transmitter Virtual) 1/2 Menu</b> .....	<b>15</b>		
Display of the Transmitter's Name (NAME) .....	15		
Display of the Transmission Power Setting (RF POWER) .....	15		
Display of Audio Input Level (INPUT LEVEL) .....	15		
Display of the Low-cut Filter Setting (LCF) .....	15		

---

# Features

The DWR-S02DN digital wireless receiver is a slot-in type wireless receiver capable of receiving two channels from digital wireless transmitters. Used in conjunction with Sony professional camcorders or the optional DWA-01D/F01D wireless adapter, the DWR-S02DN enables the construction of a fully digital ENG/EFP audio system. This receiver enables the application of multiple channels over unused television channels through the use of the built-in Sony original channel plan.

## What is DWX?

DWX refers to Sony's new digital wireless microphone system. The DWX series reflects Sony's extensive expertise in professional microphones and sound design. It represents a successful blend of Sony know-how, wireless technology renowned for stability, and cutting-edge digital audio technology.

In addition to realizing the high sound quality possible with a digital system, the DWX series supports multi-channel simultaneous operation, encrypted transmission, and metadata transmission for monitoring the status of multiple transmitters. Using a main link and a separate additional link, remote control of transmitters from the receiver is also possible. With its many advanced features, the system has the potential to revolutionize the workflow of professional applications.

## What is WiDIF-HP?

WiDIF-HP (WiDIF: Wireless Digital Interface Format, HP: High Profile) is a wireless digital audio interface format developed by Sony.

It enables highly secure transmission with high sound quality and low system latency, and supports simultaneous multi-channel operation.

## What is Cross Remote?

Cross Remote is a system that allows transmitters to be monitored and controlled from a receiver and the Wireless Studio control software installed on a computer connected to the receiver.

For example, the settings of a transmitter worn under clothing can be easily changed over the wireless link.

## Preprogrammed wireless channel plans for simultaneous multi-channel operation

The DWR-S02DN has many preprogrammed channel groups, meaning combination of wireless channels to permit simultaneous operation of multiple channels without intermodulation.

## Two-channel slot-in wireless receiver

Despite its dual-channel receiver capability, the DWR-S02DN is small enough to be mounted directly in the slot of the Sony camcorder.

## Rear mounting to camcorders

The DWR-S02DN can be rear-mounted to a range of Sony professional camcorders - using the DWA-01D/F01D wireless adapter. When used with a camcorder that has AES/EBU inputs, full-digital audio recording is also possible.

## Auto channel scanning function

The DWR-S02DN comes with two auto channel scanning functions that allows for fast, easy and safe frequency channel changes.

## Three audio codec modes

Switch between audio codec modes based on your operational needs.

*For details, see "Setting the Audio Codec Mode (CODEC MODE)" on page 14.*

## Compact, lightweight, and rugged design

The DWR-S02DN is highly compact and lightweight, maintaining a good balance even when mounted on a camcorder. In addition, it is made of magnesium die-cast and aluminum, making it extremely rugged and suitable for the harsh environment.

## Easy-to-see, full dot-matrix OLED (Organic Light-Emitting Diode) display

The quick response of the OLED display enables real-time operating conditions to be displayed clearly and accurately.

# Parts Identification

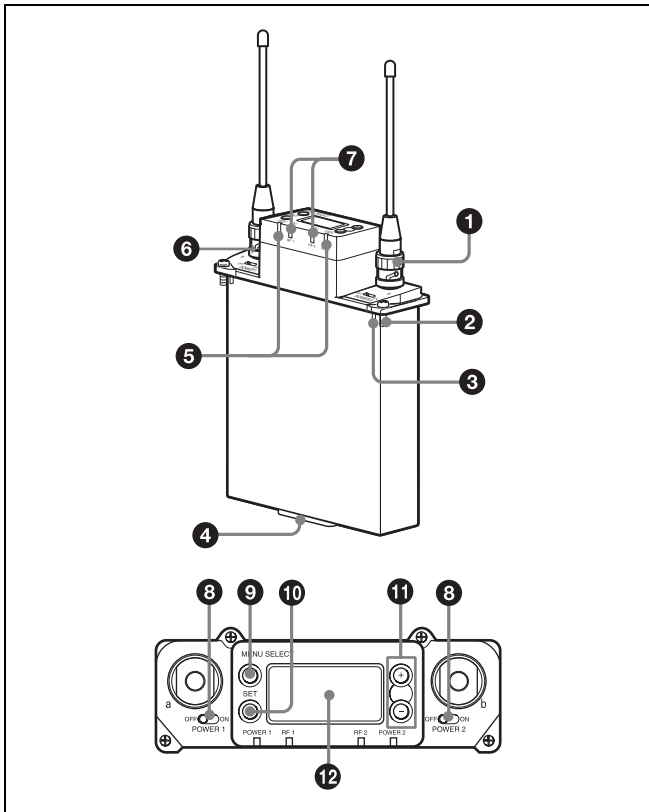

**1 Antenna and antenna connector (BNC type)**

Connect the supplied antenna here.

**2 Mounting screw**

Use to attach the receiver to a camcorder or DWA-01D/F01D wireless adapter.

**3 Compatibility pin**

Prevents the attachment of an incompatible camcorder or adapter.

**4 Accessory connector**

Use to connect the receiver to a camcorder or DWA-01D/F01D wireless adapter. Power, audio, and control signals are sent through this connector.

**5 POWER indicator**

Lights up green when the power is on. The POWER1 and POWER2 indicators indicate the power status of tuner 1 and tuner 2, respectively.

**6 USB connector**

Connecting an optional keyboard to this connector allows menu operation to be performed on the keyboard. Connecting the transmitter to this connector through the supplied USB cable allows an encryption key to be exchanged with the transmitter.

*For details on the use of a USB keyboard, see “Using a USB Keyboard” on page 10.*

*For details on encryption key exchange, see “Using the Encrypted Transmission Function” on page 8.*

**7 RF (radio frequency) indicators**

Indicate the RF input level of tuner 1 and tuner 2. The indicators that light up depend on the RF squelch function setting as follows:

**When the RF (radio frequency) squelch level is set to OFF:**

**On in green:** 25 dB $\mu$  or more

**On in red:** 20 dB $\mu$  to 25 dB $\mu$

**Off:** Less than 20 dB $\mu$

**When the RF (radio frequency) squelch level is set to 20 dB $\mu$ :**

**On in green:** 30 dB $\mu$  or more

**On in red:** 20 dB $\mu$  to 30 dB $\mu$

**Off:** Less than 20 dB $\mu$

**8 POWER switches**

Turn tuner 1 and tuner 2 on or off individually.

**9 MENU SELECT (menu selection) button**

Selects the displayed menu.

**10 SET button**

Changes the item to be set or enters the selected function or parameter value.

**11 + or – button**

Use to select a function or value.

If you set the POWER switch on tuner 1 or tuner 2 to ON while holding down the + button, the tuner that you turned ON will begin the scanning operation of the clear channel scan function.

If you set the POWER switch on tuner 1 or tuner 2 to ON while holding down the – button, the tuner that you turned ON will begin the pairing operation of the wireless remote control function.

**12 Display section**

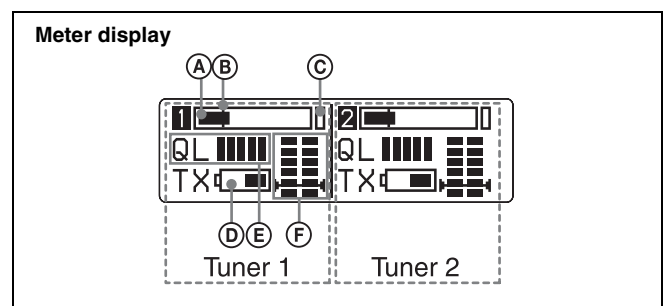

**A Audio input level meter**

Indicates the input signal level.

**B Reference level gage**

Indicates the reference input level.

–58 dBu (–60 dBV) is indicated when the input level is set to “MIC” on the transmitter, and +4 dBu when the input level is set to line.

© **Peak indicator**

Warns of excessive input by lighting up when the signal is 3 dB below the level at which distortion begins.

Ⓓ **Battery indication**

Based on metadata from the transmitter, shows the transmitter's battery condition according to 8 level indications.

Replace both batteries when the battery indication starts to flash.

*For details on how to change the batteries on the transmitter, refer to the operating instructions supplied with the transmitter.*

Ⓔ **Signal quality level meter**

Indicates the quality of the RF signal reception.

The occurrence of many data errors during a given interval reduces the height of the bar graph.

This meter allows you to monitor signal deterioration that may occur when there is noise or when the transmitter is too far from the receiver.

Ⓕ **RF level meter**

Indicates the RF input level. The number of segments that light up depends on the input level.

When the squelch function is set, the squelch level is indicated on the RF level meter.

When the RF input level drops below the squelch level, the output signal is muted.

---

# Preparation

---

## Attaching to a Camcorder

This receiver can be inserted into a slot provided on compatible Sony camcorders.

The audio signal, which is converted to digital by the digital wireless transmitter, can be recorded as is to the camcorder, allowing you to create a fully digital system.

- 1 Remove the cover from the slot for the wireless receiver on the camcorder, and insert the receiver into the slot.

To avoid inserting the receiver in the wrong direction, confirm the location of the mounting screws and compatibility pin before inserting the wireless receiver.

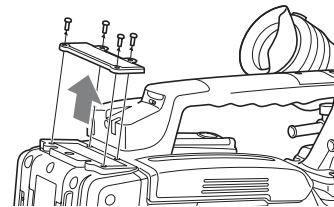

- 2 After inserting the receiver completely into slot, securely fasten the four mounting screws.

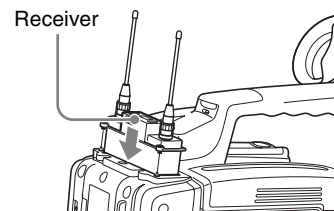

*For details about operating the camcorder with the receiver, refer to the operating instructions supplied with the camcorder.*

**Note**

If the camcorder is not compatible with the receiver, the compatibility pin on the receiver will make it impossible to insert the receiver into the slot.

*For details on compatible camcorders, consult a Sony sales representative.*

---

## Using the DWA-01D/F01D Wireless Adapter

Attaching the receiver to the DWA-01D/F01D wireless adapter allows them to be used as a portable wireless receiver.

*For details, refer to the operating instructions supplied with the adapter.*

---

## Setting the Receiving Channel

The receiver provides groups of channels for interference-free transmission. When using multiple wireless microphones and transmitters (simultaneous multi-channel operations) within the same area, selecting the same group and using a channel within that group can prevent signal interference.

---

### Selecting the Frequency Band / Group / Channel

Set the frequency band (BAND), group (GP), and channel (CH) as follows.

*For details on the groups and channels included in each frequency band, refer to “Sony Digital Wireless Microphone System Frequency Lists” on the supplied CD-ROM.*

*For details on menu operations, see “Basic Menu Operations” on page 11.*

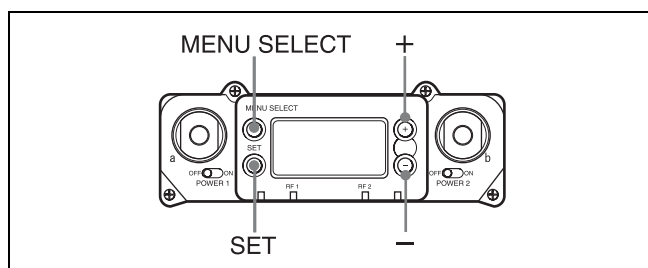

- 1** Press the MENU SELECT button repeatedly until the RX1/RX2 menu is displayed.
- 2** Press the + or – button repeatedly until the BAND screen is displayed.
- 3** Hold down the SET button until the item to be set flashes.
- 4** Press the + or – button repeatedly to select a frequency band.
- 5** Press the SET button to confirm the selection.
- 6** Press the + or – button repeatedly until the GP/CH screen is displayed.
- 7** Hold down the SET button until the item to be set flashes.
- 8** Press the + or – button repeatedly to select a group.
- 9** Press the SET button to confirm the selection.

The channel indicator starts flashing.

**10** Press the + or – button repeatedly to select a channel.

**11** Press the SET button to confirm the selection.

### When the wireless remote control function is operating:

When you change the BAND/GP/CH setting on the receiver, you can send the BAND/GP/CH setting to the transmitter that is paired with the receiver.

#### Note

If the receiving channel (CH) configured on the receiver is a channel for which use with the wireless remote control function is restricted on the transmitter side, the UNMATCH screen appears.

In such cases, change the receiving channel on the receiver. If you want to use the restricted channel, set REMOTE to OFF in the transmitter's menu to release the channel restriction, and manually configure the transmitter's channel.

### About use of the same group and channel by adjacent systems

When the same group and channel are being used by two or more systems that are within sight of each other and are separated without partitions or obstacles in wide open place, each system should be at least 100 meters away from the others to avoid interference.

---

## Using the Active Channel Scan Function

This function scans for a Sony digital wireless frequency from the frequency lists within the GP (group) selected during the GP/CH selection function.

#### Required condition for the detection:

- Sony digital wireless signal
- Above the RF squelch level of the receiver
- The setting of the encrypted transmission function is correct
- The audio codec mode settings match

**1** Press the MENU SELECT button repeatedly until the RX1/RX2 menu is displayed.

**2** Press the + or – button repeatedly until the ACT CH SCAN indication is displayed.

**3** Hold down the SET button until the item to be set flashes.

**4** Press the + or – button repeatedly to select YES.

Scanning starts. When a Sony digital wireless frequency is detected, scanning stops and the frequency is displayed.

If you select NO, the scanning function will be cancelled.

**5** If you decide on that frequency after checking it out, press the + or – button repeatedly to select SET, and then press the SET button.

To search for another frequency, press the + or – button repeatedly to select CONTINUE, and then press the SET button.

#### Note

If a Sony digital wireless frequency within the group is not found by the second try, scanning is cancelled.

---

## Using the Clear Channel Scan Function

This function searches for a channel that is not being used by another wireless device or by a TV station. This function makes it easy to find an available channel to allow the wireless microphone to be used without interference. The function searches for an empty channel among the registered frequencies within the GP (group) selected by the GP/CH selection function.

In addition to using the following procedure, you can also set the POWER switch on tuner 1 or tuner 2 to ON while holding down the + button to start the clear channel scan function on the tuner that you turned ON.

**1** Press the MENU SELECT button repeatedly until the RX1/RX2 menu is displayed.

**2** Press the + or – button repeatedly until the CLR CH SCAN indication is displayed.

**3** Hold down the SET button until the item to be set flashes.

**4** In the CLR CH SCAN indication, press the + or – button repeatedly to select YES.

Scanning starts. When an empty channel is detected, scanning stops and the frequency is displayed. If you select NO, the scanning function will be cancelled.

**5** If you decide to use that channel, press the + or – button repeatedly to select SET, and then press the SET button.

When the wireless remote control function is operating, the group/channel setting can be sent to the transmitter.

To search for another empty channel, press the + or – button repeatedly to select CONTINUE, and then press the SET button.

#### Notes

- If an empty channel within the group is not found by the second try, scanning is cancelled.
- If the receiving channel (CH) configured on the receiver is a channel for which use with the wireless remote control function is restricted on the transmitter side, the

UNMATCH screen appears.

In such cases, change the receiving channel on the receiver. If you want to use the restricted channel, set REMOTE to OFF in the transmitter's menu to release the channel restriction, and manually configure the transmitter's channel.

---

## Using the Encrypted Transmission Function

This receiver is capable of receiving scrambled signals from Sony digital wireless transmitters. This function prevents hacking of the signal.

To use this function, select one of the following encrypted transmission modes:

**Secure key mode:** A secure key that is automatically generated by the transmitter is used by both the transmitter and receiver in this one-to-one encrypted transmission method.

**Password mode:** You choose a password of up to eight characters that can be set for multiple transmitters and receivers. This enables encrypted transmission to be conducted within a group.

### Note

Make sure the same mode is set on the transmitter and receiver.

---

## Using Secure Key Mode (SECURE KEY)

Use this mode for one-to-one encrypted transmission between one transmitter and one receiver.

An encryption key that cannot be read from the outside is automatically generated by the transmitter. This key is transmitted to the receiver through a USB connection or the RF REMOTE function, enabling encrypted transmission to take place.

The encryption key used by the transmitter and receiver is newly generated for each key transmission, resulting in highly secure communication.

The encryption key used between the transmitter and the receiver is saved when the power is turned off, so the encrypted transmission can be resumed the next time the power is turned on.

### 1 Preparing the receiver (this unit)

- ① With the ENCRYPTION indication on (in the RX1/2 menu), hold down the SET button until the item to be set flashes.
- ② Press the + or – button repeatedly to select SECURE KEY, and then press the SET button.

### 2 Preparing the transmitter

Set SECURE KEY on the transmitter that will transfer the encryption key.

*For details on transmitter operations, refer to the operating instructions supplied with the transmitter.*

### 3 Exchanging the encryption key

On the receiver, select USB or REMOTE (wireless remote) as the method for encryption key exchange.



When the RF REMOTE function is off, REMOTE cannot be selected.

**When you select USB:**

Connect the transmitter to the receiver using a USB cable (not supplied) and the USB adapter cable (supplied with the transmitter). (To make this connection with a USB cable, you must remove the antenna next to the USB connector.)

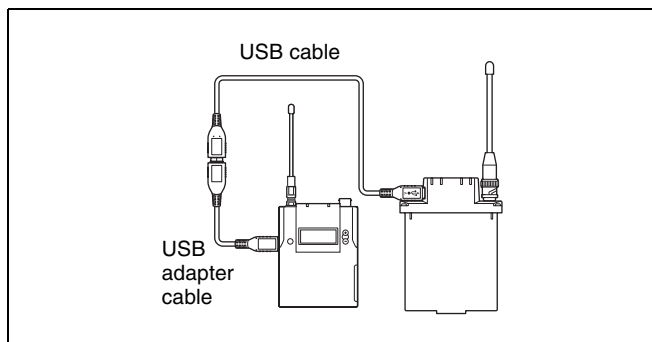

When you connect the USB cable, the encryption key is exchanged automatically, and encrypted transmission in secure key mode begins. Remove the USB cable.

**When you select REMOTE:**

The receiver searches for a transmitter that it has been paired with. After the receiver detects the transmitter, the transmitter exchanges the encryption key with the receiver and encrypted transmission begins.

- 5 On the transmitter, set the same password that was set on the receiver.

*For details on transmitter operations, refer to the operating instructions supplied with the transmitter.*

**Note**

It is recommended that you change the password periodically.

---

## Using Password Mode (PASSWORD)

Set this mode when multiple transmitters are paired with multiple receivers for encrypted transmission. If the transmitters and receivers are set with the same user-designated password, the audio signal can be decoded. This mode is useful when multiple transmitters and receivers are used as a single group, or when the audio signal from one transmitter is received by multiple receivers at the same time.

- 1 With the ENCRYPTION indication on (in the RX1/2 menu), hold down the SET button until the item to be set flashes.
- 2 Press the + or – button repeatedly to select PASSWORD, and then press the SET button.
- 3 Enter a password of up to 8 characters on the receiver.
  - + : The first press on the + button displays the character set. You can then use the + and – buttons to select the desired character. And then, pressing the SET button adds the selected character to the end of the current password.
  - : Deletes the last character in the current password.
  - SET: Enters the character or edited password.
- 4 Set the encrypted transmission function on the transmitter to PASSWORD.

# Using a USB Keyboard

Connecting an optional USB keyboard to the receiver allows you to perform menu operations and enter your password for the encrypted transmission function from the keyboard.

A Micro USB connector is used on the receiver. Use the USB adapter cable supplied with the transmitter to connect the keyboard. (When a USB cable is connected to the receiver, you must remove the antenna on the USB connector side.)

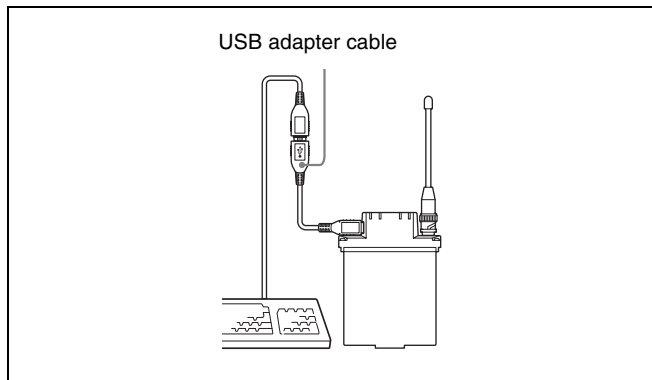

## Performing menu operations

You can use a USB keyboard to perform the same menu operations that you perform on the receiver.

The receiver buttons correspond to the following keys on a USB keyboard:

Buttons on the receiver	USB keyboard
MENU SELECT	← →
SET	ENTER
+	↑
-	↓

## To enter your password

You can use a USB keyboard to enter your password during encrypted transmission.

### Characters that can be entered from a USB

**keyboard:** 0, 1, 2, 3, 4, 5, 6, 7, 8, 9, A, B, C, D, E, F, G, H, I, J, K, L, M, N, O, P, Q, R, S, T, U, V, W, X, Y, Z

**Special key:** Backspace (BS), and Delete key (DEL)

### Notes

- The number keys on the keyboard cannot be used.
- This receiver is compatible with English-language keyboards only.
- USB keyboards with multiple functions, such as USB hub and pointing device, cannot be used.
- Power to the connected keyboard is supplied by the USB connector on the receiver. The power rating is 100 mA. Keyboards that consume more power than that cannot be used.
- Do not leave the receiver connected to the keyboard when not in use. If you do, the batteries in the receiver will be drained more quickly.
- Text editing should be done with the alphabet, BS, DEL and Enter keys.

# Menu Displays and Detailed Settings

## Menu Structure and Hierarchy

### Menu structure

The receiver has 3 kinds of menu, as follows:

#### UTILITY menu

A menu that includes meter indications, functions used in combination with the DWA-01D/F01D wireless adapter, and settings for the organic light-emitting diode display.

#### RX1/RX2 (tuner 1/2) menu

A menu that includes tuner setting functions.

#### TX1/TX2 (virtual transmitter 1/2) menu

A menu that allows you to check the settings on the transmitter currently in communication with the receiver (tuner 1 or tuner 2).

# Menu hierarchy

## MENU SELECT

- UTILITY
  - Meter indication
  - AES/EBU LVL@MIC
  - SYNC SOURCE
  - WORD SYNC 75ohm
  - ANALOG OUTPUT 1
  - TIME
  - BRIGHTNESS
  - DIMMER MODE
  - FACTORY PRESET
  - VERSION

- RX1
  - GP/CH
  - BAND
  - ACT CH SCAN
  - CLR CH SCAN
  - RF SQUELCH
  - ENCRYPTION
  - CODEC MODE
  - SYSTEM DELAY

- TX1
  - NAME
  - RF POWER
  - INPUT LEVEL
  - LCF
  - POWER SAVE
  - TIME
  - +48V
  - RF REMOTE

- RX2
  - GP/CH
  - BAND
  - ACT CH SCAN
  - CLR CH SCAN
  - RF SQUELCH
  - ENCRYPTION
  - CODEC MODE
  - SYSTEM DELAY

- TX2
  - NAME
  - RF POWER
  - INPUT LEVEL
  - LCF
  - POWER SAVE
  - TIME
  - +48V
  - RF REMOTE

To UTILITY menu

# Basic Menu Operations

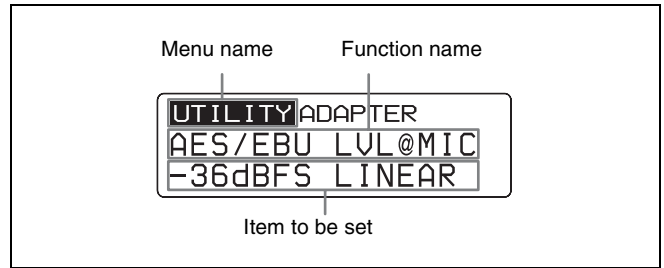

**1** Press the MENU SELECT button repeatedly to select the menu.

Each time you press the MENU SELECT button, the menu changes in the following order:

UTILITY, RX1, TX1, RX2, TX2, UTILITY

**2** Press the + or – button repeatedly until the function to be set appears.

Each time you press the + or – button, the item to be set changes.

*For details, see “Menu hierarchy” on page 11.*

**3** Hold down the SET button until the item to be set flashes.

**4** Press the + or – button to change the setting.

**5** Press the SET button to enter the setting.

**Note**

When the tuner is turned off, the menus corresponding to that tuner are not displayed.

---

# UTILITY Menu

For details on menu operation, see “Basic Menu Operations” on page 11.

The UTILITY menu includes items related to the basic receiver settings, including meter displays. These functions and parameters are explained here. Underlined items are the factory setting.

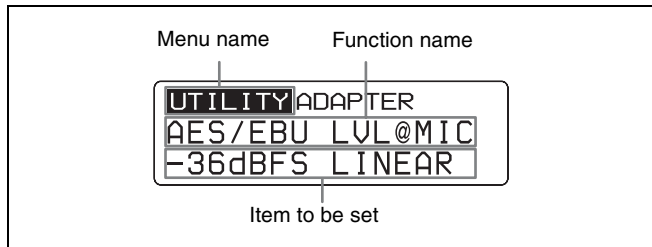

## Note

The functions indicated by “ADAPTER” (from the AES/EBU LVL@MIC function to the ANALOG OUTPUT1 function) in the upper-right corner are related to the AES/EBU output when the receiver is used in conjunction with the optional DWA-01D/F01D wireless adapter. The function does not operate even when used with a compatible Sony slot-in type camcorder.

---

## Selecting the AES/EBU Output Reference Level (AES/EBU LVL@MIC)

Selects reference level for the AES/EBU output of the optional DWA-01D/F01D wireless adapter. The setting of this function is invalid when the audio input level of the sending transmitter is set to LINE (–20 dBFS headroom signal).

## Note

The function does not operate for analog output.

- 36 dBFS LINEAR:** The audio signal from the transmitter is output with a headroom of 36 dB.
- 20 dBFS LIMITER:** The reference level is changed to –20 dBFS in conformity with the normal AES/EBU interface and the audio signal from the transmitter is compressed.
- 20 dBFS ST LIMIT:** The reference level is changed to –20 dBFS (as in the –20 dBFS LIMITER mode above) and audio signal compression is linked for tuner 1 and tuner 2. Select this setting when sending stereo audio signals using 2 transmitters.

---

## Selecting the Sync Signal (SYNC SOURCE)

Selects the sync signal source for the receiver when it is attached through the optional DWA-01D/F01D wireless adapter. The receiver supports an external sync signal (word clock) of 32 kHz –6% to 96 kHz +6%.

For details on locking the sync signal, refer to the operating instructions supplied with the adapter.

**INTERNAL:** The internal sync signal (48 kHz) is used.

**AUTO:** The external sync signal is used on a priority basis. When there is no external sync signal input, the internal sync signal is used automatically. The currently selected sync signal is displayed “INTERNAL” or “EXTERNAL.”

**EXTERNAL:** Synchronization with an external word clock signal. The current synchronization status is displayed “UNLOCK” or “LOCK.”

## Note

When “EXTERNAL” is selected, digital signals and analog signals will be output only if there is an external word clock signal input.

---

## Terminating the Sync Signal

(WORD SYNC 75ohm)

This function provides termination for the WORD SYNC connector on the DWA-01D/F01D wireless adapter.

**ON:** 75-ohm termination is added.

**OFF:** 75-ohm termination is not added.

## Note

When the receiver is turned off, the termination is released.

---

## Selecting Output 1 (ANALOG OUTPUT1)

Selects the OUTPUT1 connector of the DWA-01D/F01D wireless adapter.

When the OUTPUT2 connector of the adapter is being used for AES/EBU output, the OUTPUT1 connector can be used for sub-output.

**RX1:** Outputs the audio signal received on tuner 1.

**RX2:** Outputs the audio signal received on tuner 2.

**RX1+2:** Mixes and outputs the audio signals received on tuners 1 and 2.

---

## Showing the Accumulated Use Time (TIME)

You can display the accumulated battery use time as a rough estimate of total receiver usage. The factory setting is “00:00”.

## Resetting the accumulated time indication

- 1 Hold down the SET button until the time indication flashes.
- 2 Press the – button so “00:00 RESET” appears, and then press the SET button.

---

## Setting the Brightness of the Display (BRIGHTNESS)

Ten levels of brightness can be selected for the organic light-emitting diode display.

The selectable settings are the following:  
(Dark) **1 2 3 4 5 6 7 8 9 10** (Bright)

---

## Automatic Dimming of the Display (DIMMER MODE)

The organic light-emitting diode display can be set to dim or turn off after a certain amount of time.

**AUTO OFF:** The display turns off after 30 seconds. The display goes on again when you press the SET, +, or – button.

**AUTO DIMMER:** The display dims after 30 seconds. The display becomes bright again when you press the SET, +, or – button.

**ALWAYS ON:** The display stays on at the brightness level set with the BRIGHTNESS function.

---

## Resetting Parameters to their Factory Settings (FACTORY PRESET)

All parameter settings can be returned to their factory settings.

Holding down the SET button until a message appears asking for confirmation. Press the + or – button repeatedly to select YES, and then press the SET button to enter. The receiver parameters are reset to their factory settings.

---

## Displaying the Software Version (VERSION)

The version of the receiver software can be displayed.

---

## RX (tuner) 1/2 Menu

For details on menu operation, see “Basic Menu Operations” on page 11.

Use this menu to set the digital wireless receiver functions (the main functions of this receiver).

The following shows the US model display.

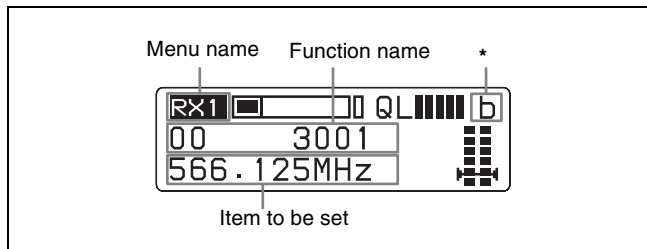

\* The antenna currently selected by the diversity function is indicated by “a” or “b”.

---

## Group/Channel Selection (GP/CH)

See “Carrier Frequencies and Channel Steps” on page 24 for factory settings.

For details, see “Selecting the Frequency Band / Group / Channel” on page 6.

---

## Frequency Band Selection (BAND)

See “Carrier Frequencies and Channel Steps” on page 24 for factory settings.

For details on the groups and channels included in each frequency band, refer to “Sony Digital Wireless Microphone System Frequency Lists” on the supplied CD-ROM.

---

## Active Channel Scanning Function (ACT CH SCAN)

The active channel scan function operates.

For details, see “Using the Active Channel Scan Function” on page 7.

---

## Clear Channel Scan Function (CLR CH SCAN)

The clear channel scan function operates.

For details, see “Using the Clear Channel Scan Function” on page 7.

---

## Using the RF Squelch Function

### (RF SQUELCH)

This function disables the audio when the RF signal becomes weak and the sound quality deteriorates. This prevents interference from a nearby Sony digital wireless transmitter set at the same frequency.

**20 dB $\mu$ :** Sets the squelch level to 20 dB $\mu$ .

**OFF:** The RF squelch function does not operate.

---

## Encrypted Transmission Function

### (ENCRYPTION)

Set the parameters for the encrypted transmission function.

**SECURE KEY:** Sets the encryption key method.

**PASSWORD:** Sets the password method.

**OFF:** The encrypted transmission function is not used.

*For details, see "Using the Encrypted Transmission Function" on page 8.*

---

## Setting the Audio Codec Mode

### (CODEC MODE)

Set the audio codec mode.

If there is a transmitter paired with this receiver, the audio codec mode of the transmitter is also switched at the same time.

**MODE1:** This audio codec mode is compatible with the first generation DWX series.

**MODE2:** This audio codec mode reduces the delay time. Audio quality is also improved compared with MODE1. We recommend using this mode under normal circumstances.

**MODE3:** This audio codec mode prioritizes stable transmission performance. Additional signal processing is used to suppress noise and audio interruptions caused by unexpected interference, resulting in more reliable transmission.

## Audio delay time when transmitting and receiving

The audio delay time matched on the transmitter side and receiver side for each mode is as follows.

### Analog output in combination with the DWA-01D/F01D

**MODE1:** 3.6 msec

**MODE2:** 2.7 msec

**MODE3:** 5.1 msec

### AES/EBU output in combination with the DWA-01D/F01D

**MODE1:** 3.4 msec

**MODE2:** 2.5 msec

**MODE3:** 4.9 msec

## Digital connection with a camcorder

**MODE1:** 3.4 msec

**MODE2:** 2.3 msec

**MODE3:** 4.8 msec

---

## Display of the Audio Signal Delay

### Time (SYSTEM DELAY)

The delay between the time the audio signal is input on the digital wireless transmitter and the time it is output on the receiver is displayed.

Because of the time that it takes for a digital wireless microphone to process an audio signal, a delay arises between input on the transmitter and output on the receiver. The indication of this delay time is important when audio signals are also being received from analog devices, which produce no delay.

**D:** Delay time between input on the transmitter and digital output on the receiver

**A:** Delay time between input on the transmitter and analog output on the receiver

(When the receiver is inserted in the camcorder slot, the time is not indicated because only the digital interface operates.)

---

# TX (Transmitter Virtual) 1/2 Menu

For details on menu operation, see “Basic Menu Operations” on page 11.

The Sony digital wireless transmitter sends not only digital audio signals, but also various other information (metadata) related to transmitter settings. The receiver can display such metadata received from a transmitter using the TX (transmitter virtual) 1/2 menu.

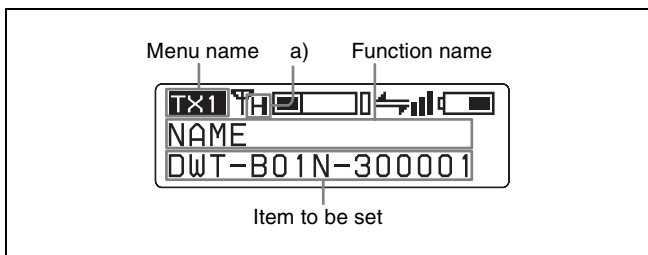
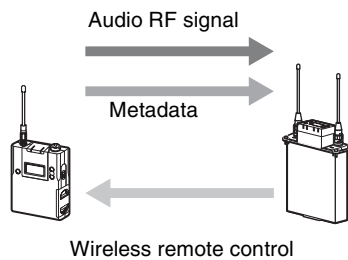

a) Indicates the power setting of the transmitter from which transmission is currently being received.

## Note

“NO DATA” appears when the transmitter is turned off or located outside the service area. “NO FUNCTION” appears when the transmitter does not have the metadata transmission function.

---

## Display of the Transmitter’s Name (NAME)

The name of the transmitter from which transmission is currently being received is displayed.

---

## Display of the Transmission Power Setting (RF POWER)

The transmission power setting of the transmitter from which transmission is currently being received is displayed.

---

## Display of Audio Input Level (INPUT LEVEL)

The audio input level setting of the transmitter from which transmission is currently being received is displayed.

---

## Display of the Low-cut Filter Setting (LCF)

The low-cut filter setting of the transmitter is displayed.

---

## Display of the Power Save Setting (POWER SAVE)

The power save setting of the transmitter is displayed.

---

## Display of Accumulated Battery Use Time (TIME)

The accumulated battery use time of the transmitter is displayed.

---

## Display of the +48V Power Setting (+48V)

The +48V power setting of the transmitter is displayed.

---

## Cross Remote (RF REMOTE)

This function must be set to allow the wireless remote control function to be used between the transmitter and receiver.

**OFF:** Stops the wireless remote control function.

**ON:** Starts the wireless remote control function with the previously paired receiver.

**PAIRING:** Executes a new pairing.

For details, see “Using the Cross Remote” on page 16.

# Using the Cross Remote

This receiver is equipped with a wireless remote control function that can be used to set the parameters (low-cut filter, attenuation operation, power save mode, etc.) of the transmitter through the TX1/2 menu. This function makes it easier to operate and manage the microphone system while in the field.

This wireless control is 2.4 GHz IEEE802.15.4 compliant and has no effect on the RF band of digital wireless audio. This function is activated when pairing is established between the transmitter and the receiver using the RF REMOTE function.

## Note

If the software version is not suitable for use with this receiver, the wireless remote control function may not function. A software update may be necessary to enable proper functioning. For details on software updates, contact your Sony service representative.

*For details on transmitter software versions that are compatible with this receiver, see “Transmitter software version” on page 22.*

## Pairing with a Transmitter

The transmitter that you want to control using the wireless remote control function is linked to the receiver via the pairing operation.

In addition to using the following procedure, you can also set the POWER switch on tuner 1 or tuner 2 to ON while holding down the – button to pair the transmitter with the tuner that you turned ON.

- 1 Press the MENU SELECT button repeatedly until the TX1/2 menu is displayed.
- 2 Press the + or – button repeatedly until the RF REMOTE indication is displayed.
- 3 Hold down the SET button until the item to be set flashes.
- 4 Press the + or – button repeatedly to select PAIRING.
- 5 Press the SET button to enter the setting.

Before proceeding to the next step, set the transmitter to be controlled to pairing mode.

*For details, refer to the operating instructions supplied with the transmitter.*

The receiver starts searching for a transmitter and then displays the transmitter name with which pairing can be executed.

During the search, pressing any operation key on the receiver will cancel pairing mode.

- 6 Press the + or – button repeatedly to select the transmitter to be paired with from among those indicated.
- 7 Press the SET button to enter the setting.

The receiver starts to communicate with the selected transmitter and the wireless remote control condition appears in the display. The condition level (indicated by ) goes up and the remote control function becomes operative.

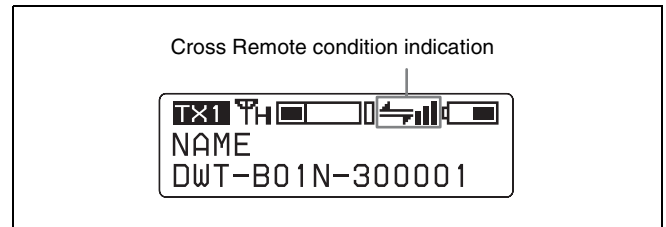





## Note

If the receiving channel (CH) configured on the receiver is a channel for which use with the wireless remote control function is restricted on the transmitter side, the UNMATCH screen appears.

In such cases, change the receiving channel on the receiver. If you want to use the restricted channel, set REMOTE to OFF in the transmitter's menu to release the channel restriction, and manually configure the transmitter's channel.

## On Cross Remote condition indication

Indicates the signal transmission condition of the wireless remote control function (4 levels).

-  : Good transmission
-  : Somewhat good transmission
-  : Somewhat poor transmission
-  : Poor transmission
-  : Unable to communicate with paired receiver

When the wireless remote control function is off, this indication does not appear.

## Using the Cross Remote with a previous pairing

With the TX1/2 menu, select RF REMOTE, and then select ON.

## Notes

- When you set RF REMOTE to ON, the transmitter will communicate with the receiver to which it was previously paired. To use the wireless remote control function with another transmitter, you must perform the pairing procedure again for that transmitter.
- Pairing with multiple transmitters is not possible.

## The following transmitter settings can be performed through Cross Remote:

- Group/channel/band setting
- RF transmission power setting
- Audio input attenuation setting
- Low-cut filter setting
- Power save setting



- +48V setting
- Audio codec mode setting

For details on the transmitter settings, see “Changing the Settings on the Transmitter” on page 17.

## Cancelling the Cross Remote

In the TX1/2 menu, select RF REMOTE, and then OFF.

## Notes on the Cross Remote

The wireless remote control function on the receiver uses the 2.4 GHz band and may thus be subject to interference from other devices.

- When pairing fails (“Pairing fail” is displayed), carry out pairing again. Successful communication between the transmitter and the receiver has not occurred within a given amount of time. Pairing may be harder to do when another receiver is engaged in pairing nearby.
- When it becomes hard to use the remote control, the remote control may be improved by switching the wireless remote control function off, then on again in the RF REMOTE display, then re-pairing with the transmitter (change to a channel with less interference).

# Changing the Settings on the Transmitter

For details on menu operation, see “Basic Menu Operations” on page 11.

You can change the settings on the transmitter that is paired with this receiver using the RX1/2 menu or the TX1/2 menu.

The following shows the US model display.

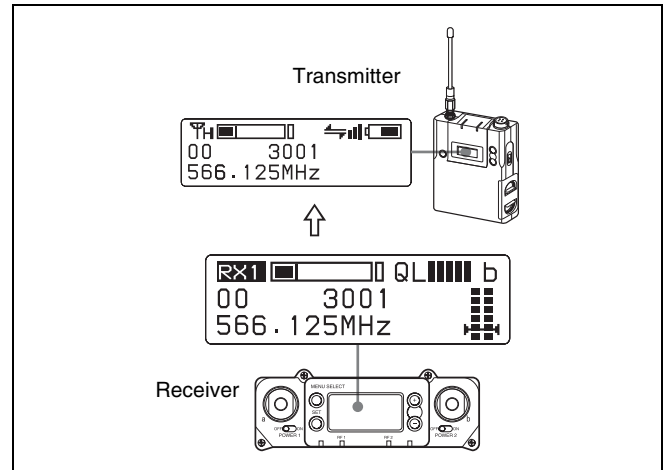

## Group/Channel Setting (GP/CH)

This setting is set through the GP/CH indication of the RX1/2 menu.

For details, see “Selecting the Frequency Band / Group / Channel” on page 6.

## Frequency Band Setting (BAND)

This setting is set through the BAND screen of the RX1/ RX2 menu.

For details, see “Selecting the Frequency Band / Group / Channel” on page 6.

## Transmission Power Setting (RF POWER)

You can change the transmission power of the transmitter.

### Note

Always perform pairing after changing the maximum RF output power setting for a transmitter. If you fail to do so, configuration of RF output power settings via the wireless remote control function may become impossible.

For details on pairing, see “Pairing with a Transmitter” on page 16.

---

## Audio Input Level Setting (INPUT LEVEL)

When the input of the transmitter is set to MIC, the value of the attenuator can be changed.

The attenuator values that can be selected depend on the transmitter function.

---

## Low-cut Filter Setting (LCF)

The low-cut filter setting of the transmitter can be changed.

### Note

The frequency selection depends on the transmitter function.

---

## Power-saving Setting (POWER SAVE)

To conserve power, this setting allows you to change the transmitter to sleep mode using the wireless remote control function.

### Note

When the transmitter changes to sleep mode, transmission of the RF audio signal and metadata is stopped. For this reason, “NO DATA” appears for all items in the TX1/2 menu, except for “SLEEP” in the POWER SAVE indication.

---

## +48V Power Setting (+48V)

Turns the +48V on the transmitter on or off.

### Note

This function may not be supported depending on the transmitter.

---

## Cross Remote Setting (RF REMOTE)

**OFF:** Stops the wireless remote control function.

**ON:** Starts the wireless remote control function with the previously paired receiver.

**PAIRING:** Executes a new pairing.

*For details, see “Using the Cross Remote” on page 16.*

---

## Audio codec mode setting

(CODEC MODE)

Set the audio codec mode.

### Note

This function may not be supported depending on the transmitter.

# Block Diagram

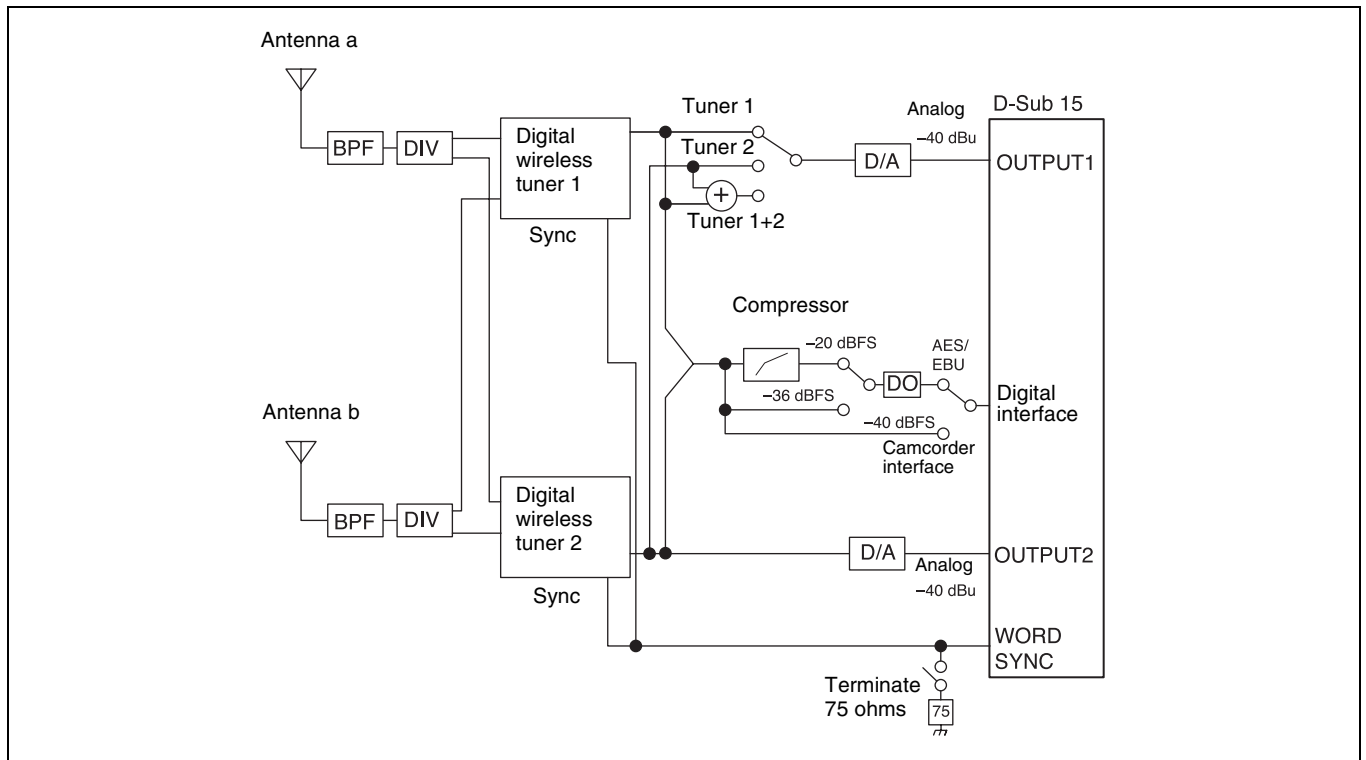

# Troubleshooting

If you encounter a problem using this receiver, use the following checklist to find a solution. For any problems with the transmitter or adapter, refer to the operating instructions supplied with the respective device. If the problem persists, consult your Sony dealer.

Symptom	Meanings	Remedy
The receiver does not turn on.	The receiver is not correctly inserted into the slot of the camcorder or the optional DWA-01D/F01D wireless adapter.	Insert the receiver until it is firmly and completely in, and then secure it with the mounting screws.
There is no sound.	The channel setting on the transmitter is different from that on the receiver.	Use the same channel setting on both the transmitter and receiver.
	The transmitter is turned off.	Check the power supply or battery of the transmitter.
	The setting of the encrypted transmission function on the receiver is different from that on the transmitter.	Confirm that the setting of the encrypted transmission function is the same on both the transmitter and the receiver.
	When the receiver is attached through the optional DWA-01D/F01D wireless adapter, the setting of the sync signal is not appropriate.	Using the sync signal selection (SYNC SOURCE) function, set the sync signal to INTERNAL. When an external sync signal is used, confirm the connection of the sync signal, and set to AUTO or EXTERNAL.
	The audio codec mode settings on the receiver and transmitter do not match.	Configure the same audio codec mode setting for both the receiver and transmitter.
The sound is weak.	The attenuation level on the transmitter is too high.	Set the attenuator on the transmitter to an appropriate level.
	The AES/EBU reference output level is set to -36 dBFS LINEAR.	Set the reference output level according to the use (see page 12).
There is distortion in the sound.	The attenuation level of the transmitter is zero or too low.	The input level of the transmitter is extremely high. Adjust the attenuation level on the transmitter so that there is no distortion to the sound.
	A LINE level signal is being input while the input level of the transmitter set to MIC.	Refer to the operating instructions supplied with the transmitter and set the input level to LINE.
Encrypted transmission does not function when using a USB connection.	The software version of the transmitter is not suitable for use with this receiver.	Refer to the transmitter software compatibility table, and confirm whether the software version of the transmitter is suitable for use with this receiver (see page 22). If it is not suitable, software update is necessary. Contact your Sony service representative.
There is sound interruption or noise.	The RF indicator lights up even when the transmitter is turned off.	Jamming radio waves are being received. Set the channel whose RF indicator on the receiver does not light up, and then set that same channel on the transmitter. When two or more transmitters are being used, change to another channel group that is unaffected by jamming radio waves. When doing this, the clear channel scan function is useful.
	Two or more transmitters are set to the same channel.	It is not possible to use two or more transmitters that are set to the same channel. Refer to the Sony digital wireless frequency lists and reset the transmitter channel.
	The channel is not set within the same channel group.	The channel plan of the receiver use is set so that no signal interference occurs when two or more transmitters are used simultaneously. Set each transmitter to a different channel within the same channel group.

Symptom	Meanings	Remedy
Wireless remote control is not possible.	Pairing has not been established between the transmitter and receiver.	Carry out pairing (see page 16).
	The receiver is too far from the transmitter for communication to occur.	Check the condition level. If it is low, decrease the distance between the transmitter and the receiver.
	The transmitter that was paired with the receiver has been paired with another receiver.	Carry out pairing again with the transmitter that you want to control.
	The software version of the transmitter is not suitable for use with this receiver.	Refer to the transmitter software compatibility table, and confirm whether the software version of the transmitter is suitable for use with this receiver (see page 22). If it is not suitable, software update is necessary. Contact your Sony service representative.
The USB keyboard does not work.	You are using a USB keyboard that is not compatible with the receiver.	Check the conditions for using a USB keyboard with the receiver (see page 10).
The display is too dark.	The display brightness is set to low.	Adjust the brightness of the display (see page 13).

---

# Important Notes on Operation

---

## Notes on Using the Receiver

- The digital wireless microphone system product must be used within a temperature range of 0 °C to 50 °C (32 °F to 122 °F).
- Operating the receiver near electrical equipment (motors, transformers, or dimmers) may cause it to be affected by electromagnetic induction. Keep the receiver as far from such equipment as possible.
- The presence of the lighting equipment may produce electrical interference over the entire frequency range. Position the receiver so that interference is minimized.
- To avoid degradation of the signal-to-noise ratio, do not use the receiver in noisy places or in locations subject to vibration, such as the following:
  - near electrical equipment, such as motors, transformers or dimmers
  - near air conditioning equipment or places subject to direct air flow from an air conditioner
  - near public address loudspeakers
  - where adjacent equipment might knock against the tunerKeep the receiver as far from such equipment as possible or use buffering material.

---

## On Cleaning

- If the receiver is used in a very humid or dusty place or in a place subject to an active gas, clean its surface as well as the connectors with a dry, soft cloth soon after use. Lengthy use of the receiver in such places or not cleaning it after its use in such places may shorten its life.
- Clean the surface and the connectors of the receiver with a dry, soft cloth. Never use thinner, benzene, alcohol or any other chemicals, since these may mar the finish.

---

## Transmitter software version

If the software version is not suitable for use with this receiver, the wireless remote control and encrypted transmission functions may not function. Refer to the following tables for transmitter software versions that are compatible with this receiver. A software update may be necessary to enable proper functioning. For details on software updates, contact your Sony service representative.

*For details on confirming the software version, refer to the operating instructions for each transmitter.*

### Transmitter Model No.: U3040, U4250

Model name	Software version
DWM-01	Ver 1.12 or later
DWT-B01/DWT-P01 (Serial No. 10999 or below)	Ver 1.22 or later
DWT-B01 (Serial No. 11001 or above)	Ver 2.13 or later
DWT-P01 (Serial No. 11001 or above)	Ver 2.12 or later

### Transmitter Model No.: Other

Model name	Software version
DWM-01	Ver 1.12 or later
DWT-B01	Ver 2.13 or later
DWT-P01	Ver 2.12 or later

---

## Audio degradation due to weak reception

In a digital wireless system, sound quality is maintained up to the maximum transmission range. Beyond this point, as the radio wave becomes weaker, data synchronization is lost and the connection finally breaks. Sony digital wireless systems suppress the occurrence of large noise between these two points as the signal weakens. As a result, digital processing is conducted in a way that allows the signal to degrade in a very natural way.

### To prevent electromagnetic interference from portable communication devices

The use of portable telephones and other communication devices near the DWR-S02DN may result in malfunction and interference with audio signals. It is recommended that portable communication devices near the DWR-S02DN be turned off.

# Specifications

## Tuner section

Type of Receiver	Slot-in (2 channels)
Transmission Method	WiDIF-HP (×2)
Type of reception	True diversity
Circuit system	Double superheterodyne
Local oscillators	Crystal-controlled PLL synthesizer
RF input terminal	BNC-R, 50 ohms
Antenna Type	Detachable
Sensitivity	20 dBμ or less (at ambient temperature 25 °C (77 °F), bit error rate = $1 \times 10^{-5}$ , no decline in S/N ratio)

## Audio section

Audio output connector	D-sub 15 pin (male) (×1)
Reference output level	Analog: -40 dBu Digital: -36 dBFS/-20 dBFS (switchable)
Dynamic range	106 dB or more (A-weighted)
T.H.D	MODE1, MODE2: 0.03% or less MODE3: 0.3% or less
Audio delay	Analog output in combination with the DWA-01D/F01D MODE1: 2.1 msec MODE2: 1.7 msec MODE3: 3.0 msec AES/EBU output in combination with the DWA-01D/F01D MODE1: 1.9 msec MODE2: 1.5 msec MODE3: 2.8 msec Digital connection with a camcorder MODE1: 1.9 msec MODE2: 1.3 msec MODE3: 2.7 msec

## General

Operating voltage	7 V DC
Consumption current	450 mA or less (at 7 V DC)
Operating temperature	0 °C to 50 °C (32 °F to 122 °F)
Storage temperature	-20 °C to +60 °C (-4 °F to +140 °F)
Wireless remote control	2.4-GHz IEEE802.15.4 compliant

Dimensions (Unit: mm (inches))

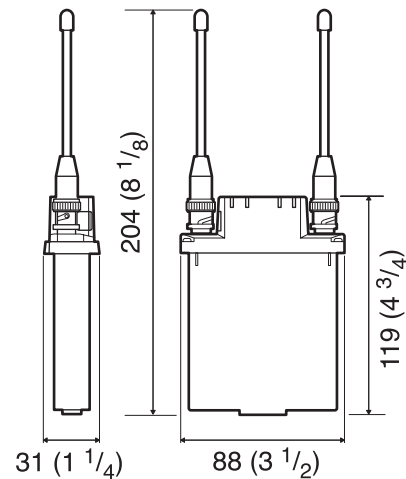

Mass	Approx. 280 g (10 oz) (including the supplied antennas)
Supplied accessories	Antenna (2) Before Using this Unit (3) CD-ROM (1) Frequency band label (1)
Optional Accessories	DWA-01D wireless adapter DWA-F01D wireless adapter

Design and specifications are subject to change without notice.

### Note

- Always verify that the unit is operating properly before use. SONY WILL NOT BE LIABLE FOR DAMAGES OF ANY KIND INCLUDING, BUT NOT LIMITED TO, COMPENSATION OR REIMBURSEMENT ON ACCOUNT OF THE LOSS OF PRESENT OR PROSPECTIVE PROFITS DUE TO FAILURE OF THIS UNIT, EITHER DURING THE WARRANTY PERIOD OR AFTER EXPIRATION OF THE WARRANTY, OR FOR ANY OTHER REASON WHATSOEVER.
- SONY WILL NOT BE LIABLE FOR CLAIMS OF ANY KIND MADE BY USERS OF THIS UNIT OR MADE BY THIRD PARTIES.
- SONY WILL NOT BE LIABLE FOR THE TERMINATION OR DISCONTINUATION OF ANY SERVICES RELATED TO THIS UNIT THAT MAY RESULT DUE TO CIRCUMSTANCES OF ANY KIND.

# Carrier Frequencies and Channel Steps

Underlined items are the factory setting.

Channel step: 25 kHz

Model No.	Frequency band	Frequency	Group/channel (factory setting)
14UC (TV14-25)	TV14-17	470.125 - 493.875 MHz	<u>00 1801 494.125 MHz</u>
	<u>TV18-21</u>	494.125 - 517.875 MHz	
	TV22-25	518.125 - 541.875 MHz	
30UC (TV30-41)	<u>TV30-33</u>	566.125 - 589.875 MHz	<u>00 3001 566.125 MHz</u>
	TV34-36	590.125 - 607.875 MHz	
	TV37	Not available	
	TV38-41	614.125 - 637.875 MHz	
30A UC (TV30-36)	<u>TV30-33</u>	566.125 - 589.875 MHz	<u>00 3001 566.125 MHz</u>
	TV34-36	590.125 - 607.875 MHz	
42LA (TV42-51)	<u>TV42-45</u>	638.125 - 661.875 MHz	<u>00 4201 638.125 MHz</u>
	TV46-49	662.125 - 685.875 MHz	
	TV50-51	686.125 - 697.875 MHz	
21CE (TV21-29)	<u>TV21-23</u>	470.025 - 494.000 MHz	<u>00 2101 470.125 MHz</u>
	TV24-26	494.025 - 518.000 MHz	
	TV27-29	518.025 - 542.000 MHz	
33CE (TV33-40)	<u>TV33-35</u>	566.025 - 590.000 MHz	<u>00 3301 566.125 MHz</u>
	TV36-37	590.025 - 606.000 MHz	
	TV38-40	606.025 - 630.000 MHz	
42CE (TV42-50)	<u>TV42-44</u>	638.025 - 662.000 MHz	<u>00 4201 638.125 MHz</u>
	TV45-47	662.025 - 686.000 MHz	
	TV48-50	686.025 - 710.000 MHz	



