

## 92-401 SHURE SM7B MICROPHONE Studio, cardioid, dynamic



### SM7B

The Model SM7B dynamic microphone has a smooth, flat, wide-range frequency response appropriate for music and speech in all professional audio applications. The microphone features shielding against electromagnetic hum generated by computer monitors, neon lights, and other electrical devices. In addition to its standard windscreen, it also includes the A7WS windscreen for close-mic speech applications.

The SM7B can be used for the following applications:

- Recording Studio applications, Instrumental and Vocal Location Recording
- Motion Picture and Television Scoring
- Television, Talk Shows, and News Desks
- Radio Announcing and Production
- Narration

#### FEATURES

- Flat, wide-range frequency response for clean and natural reproduction of both music and speech
- Switchable bass rolloff and mid-range emphasis (presence boost) settings
- Shielded against broadband interference from computer monitors and other electrical devices, rejection of electromagnetic hum
- Internal “air suspension” shock isolation virtually eliminates mechanical noise transmission
- A7WS windscreen included for close-mic vocals or narration
- Swivelling bracket with integrated stand adapter for easy mounting and precise microphone positioning
- Cardioid polar pattern, uniform with frequency and symmetrical about axis, to provide maximum rejection and minimum coloration of off-axis sound
- Rugged construction and excellent cartridge protection for outstanding reliability

#### SPECIFICATIONS

Type	Dynamic (moving coil)
Frequency Response	50 to 20,000 Hz
Polar Pattern	Cardioid
Output Impedance	EIA rated at 150Ω (150Ω actual)
Sensitivity	-59 dBV/Pa (1.12 mV) 1 Pascal=94 dB SPL (at 1 kHz, open circuit voltage)
Hum Pickup	11 dB (typical, at 60 Hz, equivalent SPL/mOe)
Polarity	Positive pressure on diaphragm produces positive voltage on pin 2 with respect to pin 3
Weight Net:	0.764 kg (1.69 lbs)
Housing	Dark grey enamel aluminium and steel case with dark grey foam windscreen.

The output level of the SM7B is -59dBV/Pa. For typical speech applications, three inches from the grille, the SM7B requires at least +60 dB of gain at the microphone preamp. Many modern microphone preamps, which are designed for the “hot” output level of condenser microphones, provide only 40 to 50 dB of gain.

## WINDSCREEN

Use the standard windscreen for general voice and instrumental applications. Use the supplied A7WS windscreen for close-talk applications, such as voice overs or radio announcements, as it offers maximum protection from plosive breath noise and creates a warmer, more intimate sound.

To install the A7WS, follow these instructions:

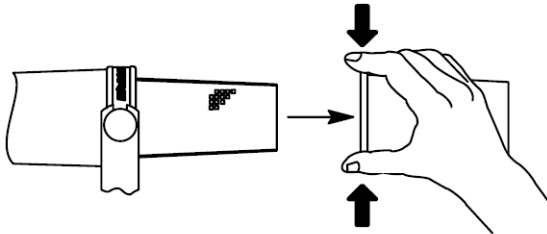

To avoid tearing the existing windshield during removal, grip from the plastic ring and the base. Remove by gently pulling and twisting.

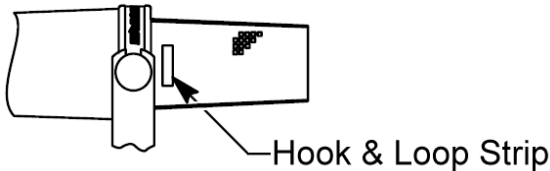

If required, adhere the supplied hook and loop strip approx. 25mm from the base of the microphone grille to secure the new A7WS windshield in place.

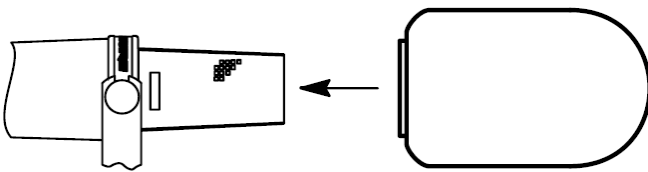

Install your new A7WS windshield by stretching over the hook and strips. Squeeze the base of the windshield to adhere to the strips. Hook and loop strip is not required inside the windshield as the material will adhere to the strip on the microphone grille.

To remove, grip the base of the windshield and pull whilst twisting.

## MOUNTING INSTRUCTIONS

The SM7B can be mounted on a microphone stand or hung from a boom, see illustrations on the next page. It is shipped in the boom mounting configuration. To set up the SM7B in the microphone stand mounting configuration, proceed as follows:

1. Remove tightening nuts on the sides.
2. Remove the fitted washers, the lock washers, the outer brass washers, and the brass sleeves.
3. Slide the bracket off the microphone. Be careful not to lose the washers still on the microphone.
4. Invert and rotate the bracket. Slide it back onto the bolts over the brass and plastic washers still on the microphone. The bracket should fit so the XLR connector faces the rear of the microphone, and the Shure logo on the back of the microphone is right-side up.
5. Replace the brass sleeves. Be sure they are seated properly within the inner washers.
6. Replace the outer brass washers, the lock washers and the fitted washers.
7. Replace the tightening nuts and tighten the microphone at the desired angle.

**NOTE:** If the tightening nuts do not hold the microphone in position, one or both of the brass sleeves may not be properly seated within all the washers.

92-401 SHURE SM7B MICROPHONE Studio, cardioid, dynamic

BOOM MOUNTING

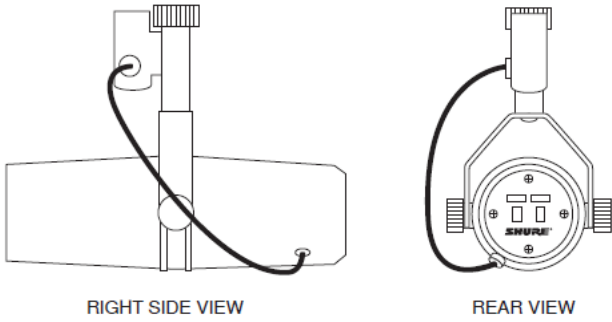

STAND MOUNTING

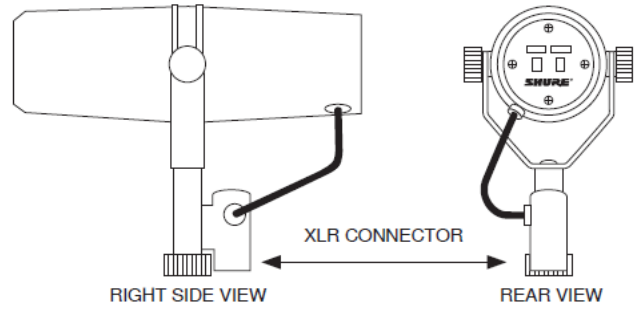

ACCESSORIES AND PARTS

Furnished Accessories	Switch Cover	RPM602	
	Windscreen - Large	A7WS	(74-6406)
Replacement Parts	Cartridge	RPM106	
	Windscreen - Small	RK345	
	Windscreen - Large	A7WS	(74-6406)
	Nut/Washer	RPM604	

FREQUENCY RESPONSE

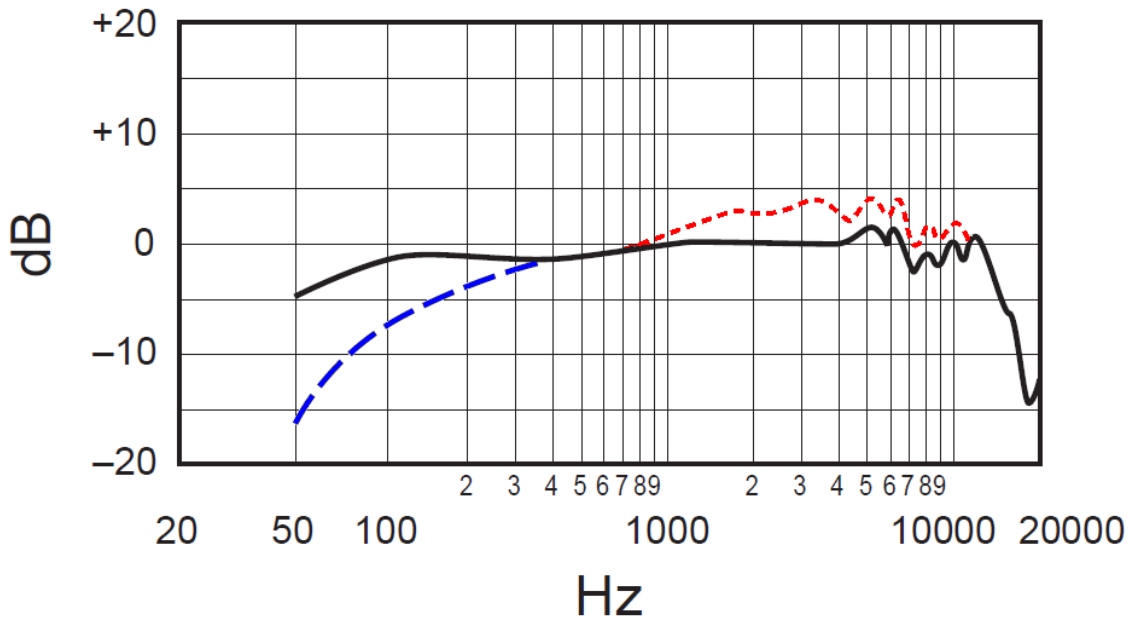

Flat Response
  Bass Roll-off
  Presence Boost



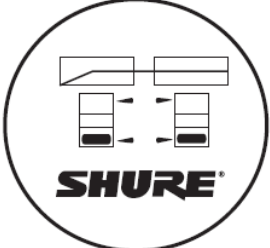

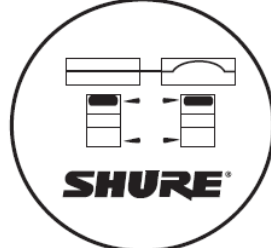

# 92-401 SHURE SM7B MICROPHONE Studio, cardioid, dynamic

## POLAR PATTERN

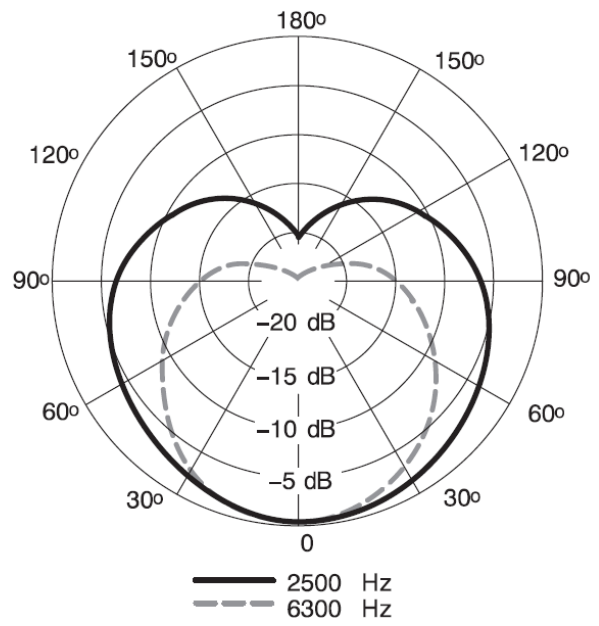
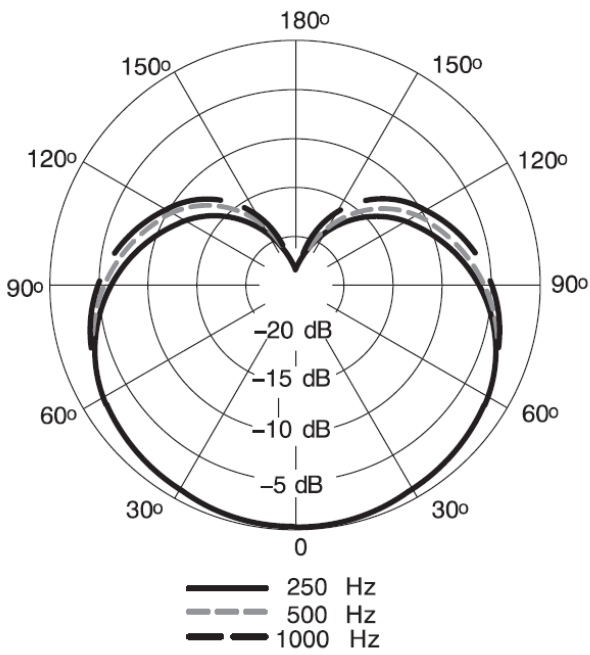

## MOUNTING ASSEMBLY – EXPLODED VIEW

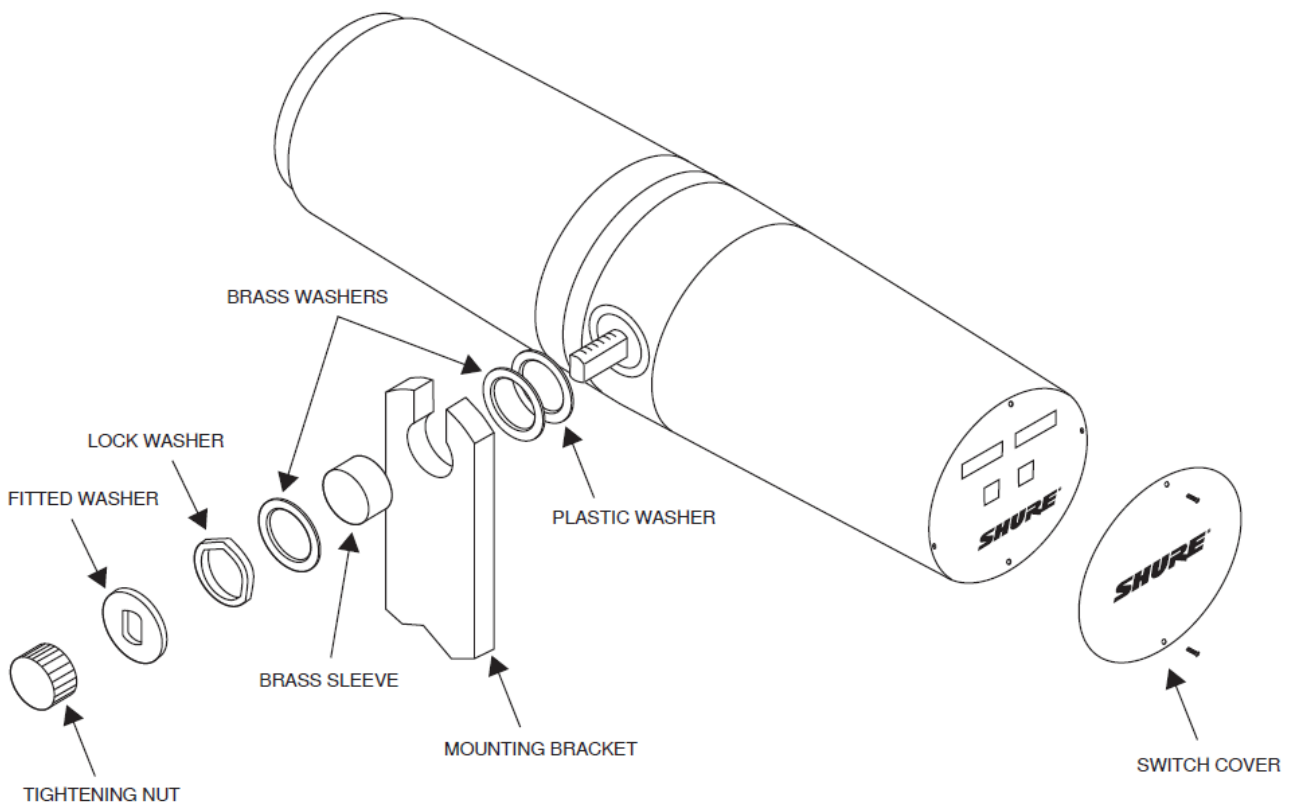

## 92-401 SHURE SM7B MICROPHONE Studio, cardioid, dynamic

### DIMENSIONS

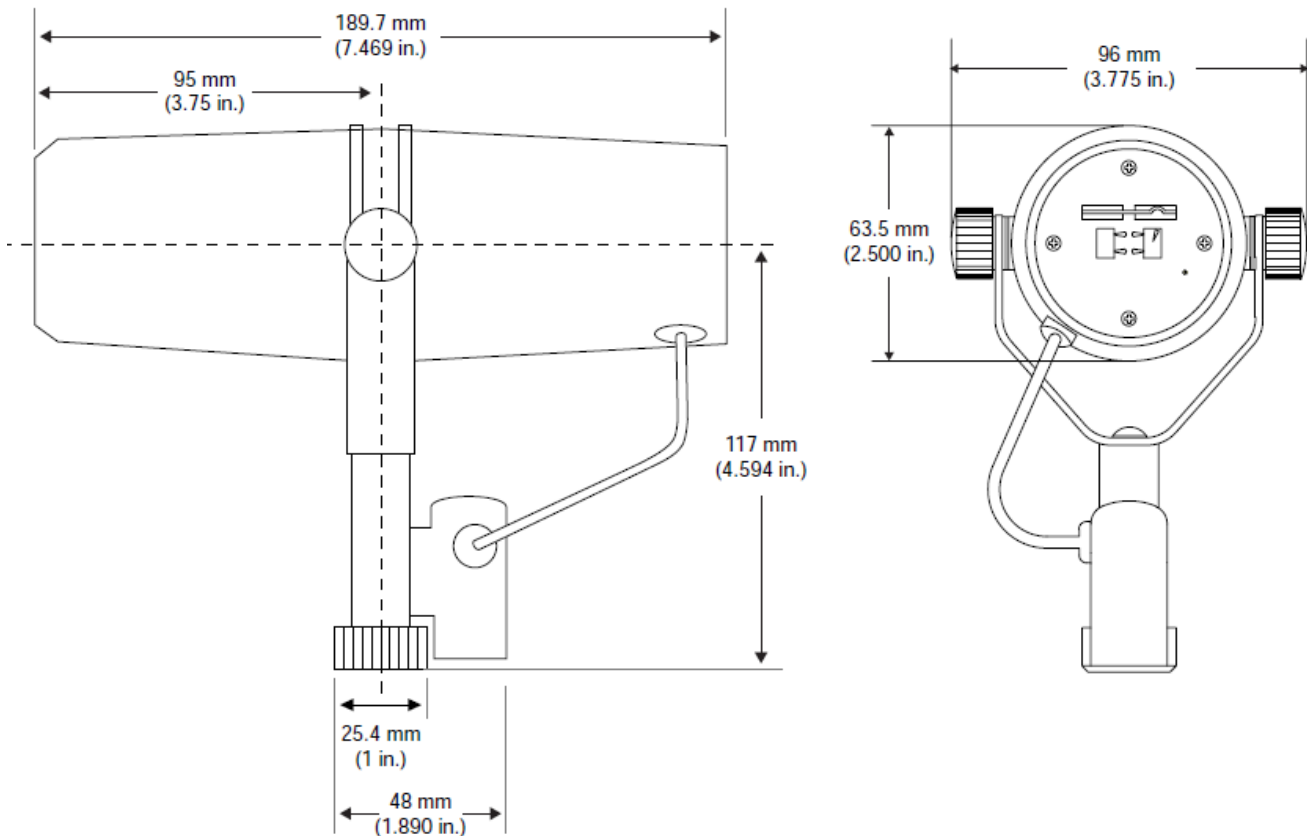

### CERTIFICATION

Eligible to bear CE Marking.

Conforms to European EMC Directive 2004/108/EC.

Meets Harmonized Standards EN55103-1:1996 and EN55103-2:1996, for residential (E1) and light industrial (E2) environments.

The Declaration of Conformity can be obtained from Authorized European representative:

Shure Europe GmbH  
Headquarters Europe, Middle East & Africa  
Department EMEA Approval  
Jakob-Dieffenbacher-Str. 12  
75031 Eppingen, Germany

Phone: +49-7262-92 49 0  
Fax: +49-7262-92 49 11 4  
E-Mail: [EMEAsupport@shure.de](mailto:EMEAsupport@shure.de)