

19" SOUNDproof Free Standing Cabinets



- ▶ Convenient for offices and indoor usage
- ▶ Very silent

19" SOUNDproof

Free Standing Cabinets

10-13

19" SOUNDproof Free Standing Cabinet 17U



14-17

19" SOUNDproof Free Standing Cabinet 32U



18-21

19" SOUNDproof Free Standing Cabinet 42U



19" SOUNDproof Free Standing Cabinets

Width: 750 mm
Depth: 1130 mm

SOUNDproof Free Standing Cabinets

General concept;

SOUNDproof Free Standing Cabinets are high quality design, for applications in office environments to reduce noise of active equipment by absorbing noise from equipment housed internally in the cabinet. Elegant appearance to blend into the office environment with the option of a wooden concept finish in Maple, Teak, Oak, Walnut, Cherry or Beech along with Black RAL 9005 paint finish to side panels and rear door.

Available in 17U, 32U and 42U heights, width 750 mm, depth 1130 mm ideal for the majority of data network, server and storage applications. SOUNDproof cabinets improves Health and Safety in the office environment by reducing noise and safe guarding office personal.

The Lande SOUNDproof cabinets has many applications in banks, hospitals, laboratories, hotels, meeting rooms, conference venues with its superior sound reduction performance it allows IT equipment to be locally sited for optimum Network performance.

The product range has been developed for banks, hospitals, laboratories, hotels, meeting rooms, conference venues, with superior sound reduction performance.

The SOUNDproof cabinet is equipped with the most high performance silent fans and ventilation system, max 29-30dB levels, to support the main objective of noise reduction performance, each cabinet is supplied as standard with a wood concept finish on front and top cover and steel rear door and side panels, both front and rear doors are lockable.

SOUNDproof series has a professional aesthetic look with decorative wood finish on the front door and roof structure with Steel rear door and side panels painted in RAL 9005 Black with fine wrinkle soft touch paint.

Completely standard and stocked product portfolio, being delivered as single piece assembled product with adjustable feet and heavy duty castor set included.

SOUNDproof series product range with optimal panel, offers optional accessories to meet the specific requirements of users.



19" SOUNDproof Free Standing Cabinets

Width: 750 mm
Depth: 1130 mm

Construction details:

Main frames are in multi folded monoblock side panel/frame system structure, produced with automated bending technology machinery. They provide a heavy duty loading capacity which has successfully tested with 1500 kg, under static loading conditions on levelling feet. Nominal loading capacity is assigned as 750 kg for safety reasons.

Monoblock multi folded top and bottom cases, fixed to the side panel/frame system with fixing hardware, providing strength and rigidity.

Cable entry;

Bottom case integrated with wide cable entry point provides maximum versatility. The rubber edged sliding mechanism on the cable entry point at the base with $w=350\text{ mm} \times d=250\text{ mm}$ allows large cabling infrastructure applications. The rubber edged sliding mechanism is max cable entry opening is $w=350 \times d=150\text{ mm}$. After inserting the cables, the rubber edged mechanism slides and holds and fixes the cables in parallel preventing dust entry.

Front door (high quality melamine coated chipboard);

Front door, wardrobe style double opening, 18 mm thickness, high quality melamine coated chipboard, with integrated barrel locking mechanism on top.

Rear door (solid metal);

Rear door, is double skin, metal, with acoustic sound emitting insulation material on the surface of both skins, integrated with handled locking unit.

Rear door also has a 3-way fan module while the hot air exhaust openings are available in both left and right sides of the rear door.

FAN module integration capacities per U height;

- 17U rear door, has 1x3 way thermostat controlled integrated fan module, with 2 pcs hot air exhaust openings included.

- 32U rear door, has 2x3 way thermostat controlled integrated fan module, with 4 pcs hot air exhaust openings included.

- 42U rear door, has 3x3 way thermostat controlled integrated fan module, with 6 pcs hot air exhaust openings included.



19" SOUNDproof Free Standing Cabinets

Width: 750 mm
Depth: 1130 mm

Construction Details:

Side Panels;

Narrow side panels; removable vertical side panels, which are lockable and removable with barrel locking. Side panels are also covered with acoustic sound emitting insulation material. From removable side panel access to vertical PDU housing is possible.

There are wide side panels, which are main frame function of the enclosure which are double skin. Both skins of the panel are covered with acoustic sound emitting insulation material.

PDU integration and capacities per U height;

17U cabinet, has at both sides a 19" PDU vertical assembly location.

32U cabinet, has at both sides 2pcs 19" PDU vertical assembly location vertical PDU can be housed.

42U cabinet, has at both sides 2pcs 19" PDU vertical assembly location vertical PDU can be housed.

Vertical PDU's do not impede on U space, universal 19" standard PDU can be assembled at the 19" rails.

19" mounting rails;

19" rails of SOUNDproof Series Free Standing Cabinets are silk-screen printed with U numbering, to help installation of equipment depends on size 1U to 42U, same from top to bottom or bottom to top. 19" rails are 2.0 mm thickness, 4 fold bending surfaces for strength and high load capacities. 19" rails are made of steel with 8-12 micron zinc plating for corrosion resistance. All 19" rails are adjustable in depth to allow flexibility when installing equipment.

Vertical cable management panels and brushed cable passage in front; the SOUNDproof Cabinets has vertical cable management panel all height in front 1set=2pcs left/right.

Vertical cable management panels allows improved cable management with integrated aluminium rings 88x60 mm, also there is 70x145 mm brushed cable passage openings in between the rings to allow cable bundles to the rear side of the cabinet.

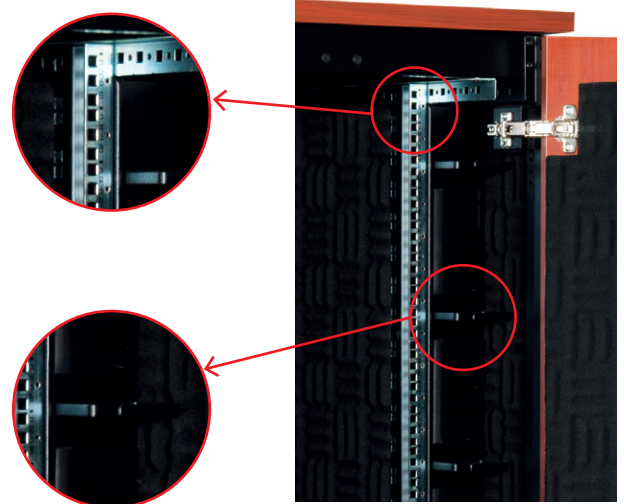

19" SOUNDproof Free Standing Cabinets

Width: 750 mm
Depth: 1130 mm

Construction details:

Top cover;

Top wood concept cover is 30 mm thickness, high quality melamine coated chipboard giving a professional appearance for the office environment.

For security the top cover is fixed from inside the cabinet and cannot be detached from outside, allowing a fully secure and sturdy top cover.

Levelling feet, caster set;

The SOUNDproof Cabinet equipped with heavy duty caster set and levelling feet. Once the Cabinet is in position the adjustable levelling can be lowered and the cabinet is secure in positioned.

The Casters and levelling feet are totally recessed. High quality melamine coated chipboard; The Wood finished options: M-Maple, C-Cherry and S-Black (Maple is standard stock chipboard option).

EN 14322; wood-based panels. Melamine faced boards for interior uses. Definition, requirements and classification; E1 quality level, formaldehyde emission E1 level, European Standard, classified as non Toxic. Indoor air concentration is less than 0,1 ppm (parts per million).

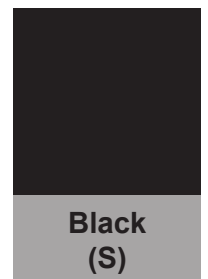
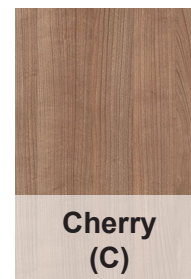
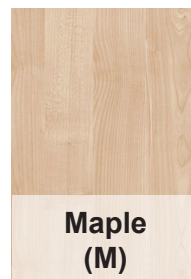

19" SOUNDproof Free Standing Cabinets

Width: 750 mm
Depth: 1130 mm

Construction details:

Acoustic Sound emitting insulation material;
High density sound emitting material, in medium, high and low frequency segments, flexy type with ventilation allowance hole spacing allows for best sound emitting performance.

- 75-100 kg/m³
- Non Flammable; (BS 476 Part 6 Class 0, Part 7 Class 1)
- Halogen Free
- Anti-Fungus
- For acoustic and sound emitting applications

UL 94 Classification of Fire resistance performance tested UL 94 V0, as Vertical Burning test.

However at same time since acoustic foam is used both in vertical and horizontal way in our SOUNDproof Racks; the acoustic foam is also tested as per UL94: horizontal burning test classified as HBF.

Covered all doors and panels, in between the double skins and internal side of the inner skins.



Sound emitting performance;

8 servers in a standard cabinet

8 servers in a SOUNDproof cabinet

8 servers in a standard cabinet			8 servers in a SOUNDproof cabinet		
70dB			Sound level of vertical driller		70dB
			Normal speech noise levels face to face		60dB
60dB					60dB
			Office background noise level		
55dB					
50dB			SOUNDproof Cabinet		50dB
40dB					40dB
Silent room					Silent room

18-21 dB noise level reduction from 1 meter distance to the enclosure

(The SOUNDproof cabinet tested according to the TS EN ISO 11546 standard, the result was Dwa= 18,5 dB)

All design features provide strength and 4 way access to equipment, easy for installations and maintenance needs whilst providing the best sound emitting performance...

19" SOUNDproof

Free Standing Cabinets

Concept Drawings

Lock, cable entry, castor set, leveling feet, hot air exhaust

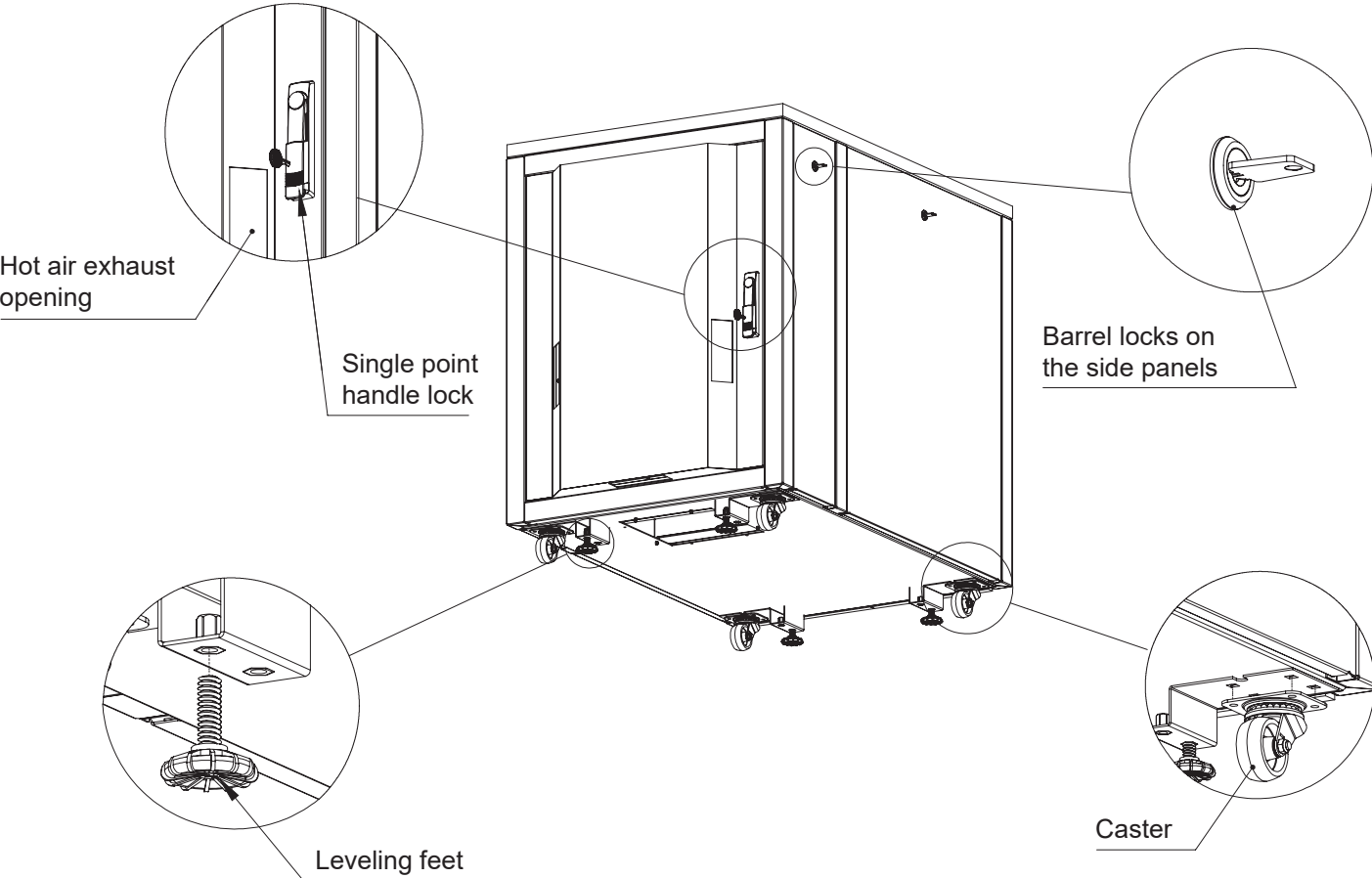

19" SOUNDproof Free Standing Cabinets Concept Drawings

Fan system, cable passage brushes, cable management rings

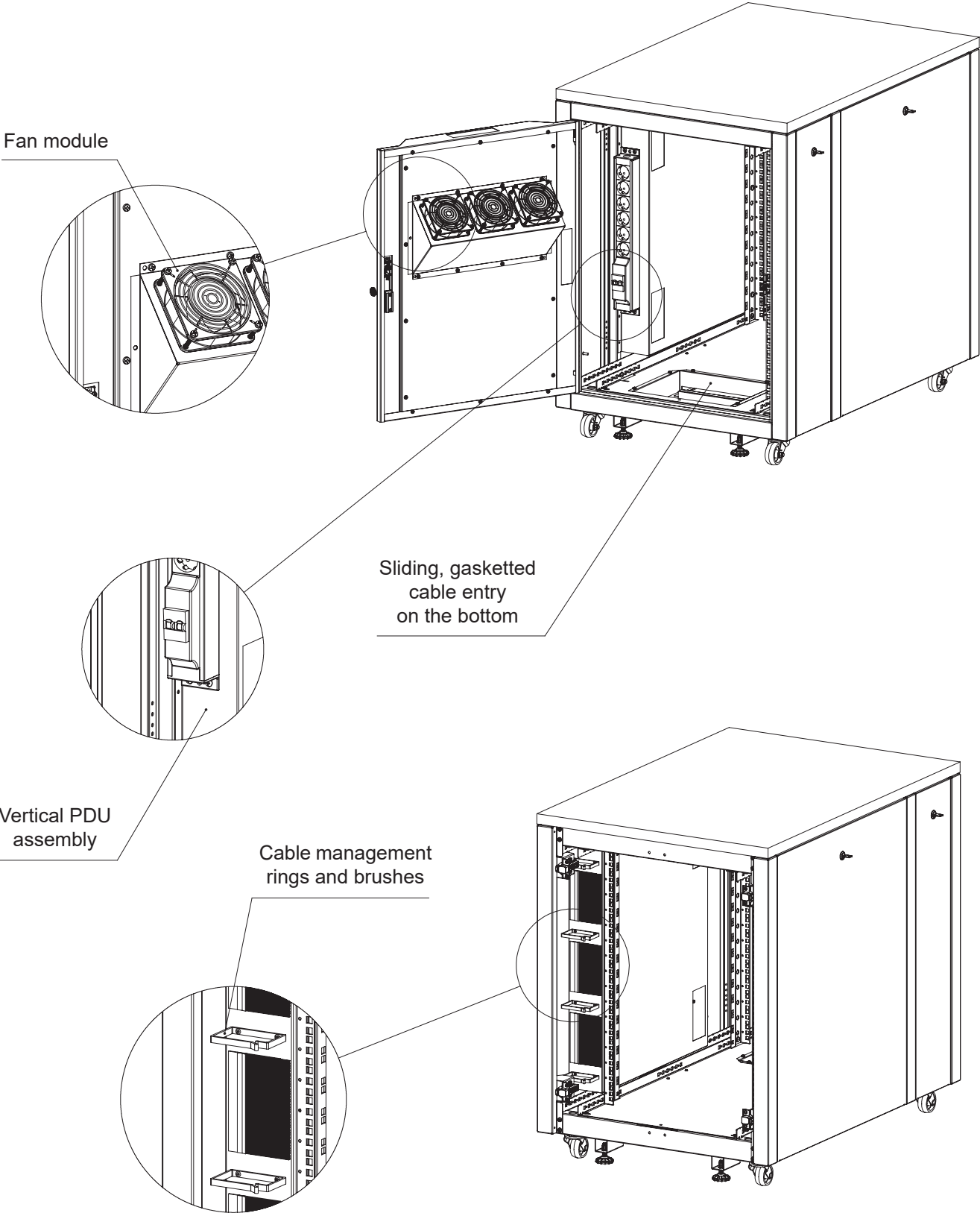

19" SOUNDproof Free Standing Cabinets

U Height: 17U

Width: 750 mm
Depth: 1130 mm

Static Load Capacity: 1500 kg.

Dynamic Load Capacity: 750 kg.
(on castors)

U Height: 17U

Standards and Compliances:



ISO 9001
Quality Management System

EN 61587-1
Mechanical Structures for
Electronic Equipment

EN IEC 60297, 19" Mounting
EN IEC 60917 Overall Cabinet
Dimensions

EN/IEC 60529 - IP20 Ingress Protection
performance

EIA/ ECA-310 (D/E) 19" 482,6 mm and
U 44,45 mm Height Sizing

TS EN ISO 11546 - Acoustic Test



CE conform to
EN 60950-1
Information Technology
Equipment-Safety-Part-1-
General Requirement



UL listed to
UL 2416, Outline of Investigation for
Audio/Video, Information and
Communication Technology Equipment
Cabinet, Enclosure and Rack
Systems; UL 60950-1 and CSA C22.2
NO. 60950-1-07, Information Technology
Equipment Safety
Part 1: General Requirements



Environment Friendly;
ISO 14001 Environmental
Management System
RoHS compliancy
%100 Recyclable Material



ISO 45001
The Occupational Health and Safety
Management System

Standard Color of Metal Parts:

E RAL 9005 Black

SOUNDproof free standing cabinets, with 19" w:750 mm
and d:1130 mm physical sizes, with max internal usable
depth 17U.



19" SOUNDproof

Free Standing Cabinets 17U

Construction Drawings

Width: 750 mm
Depth: 1130 mm

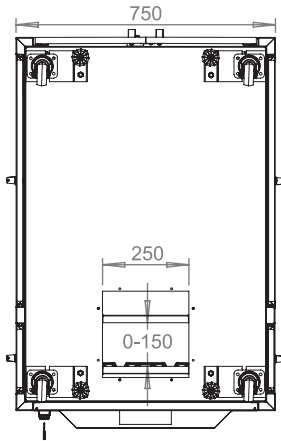

Bottom view

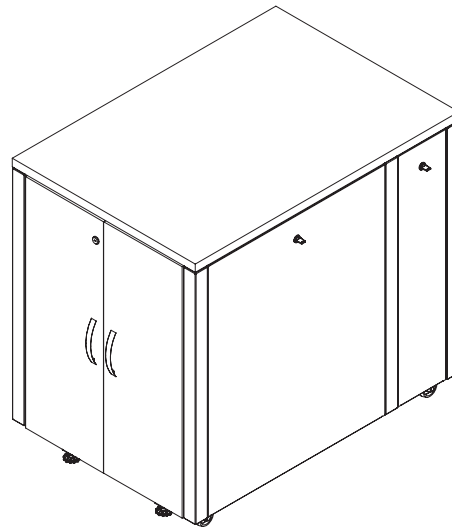

Isometric view

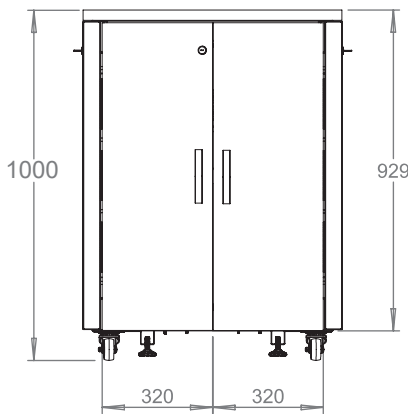

Front view

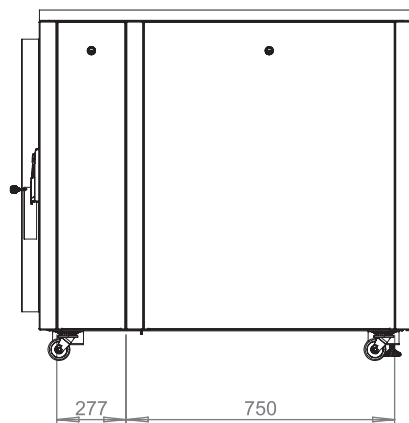

Side view

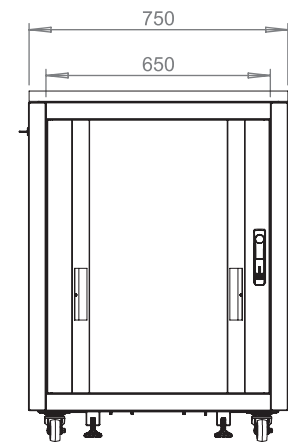

Rear view

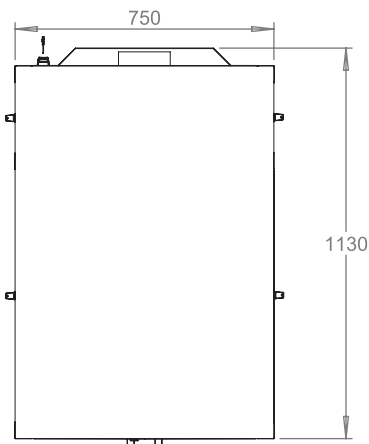

Top view

19" SOUNDproof

Free Standing Cabinets 17U

Construction Drawings

Width: 750 mm
Depth: 1130 mm

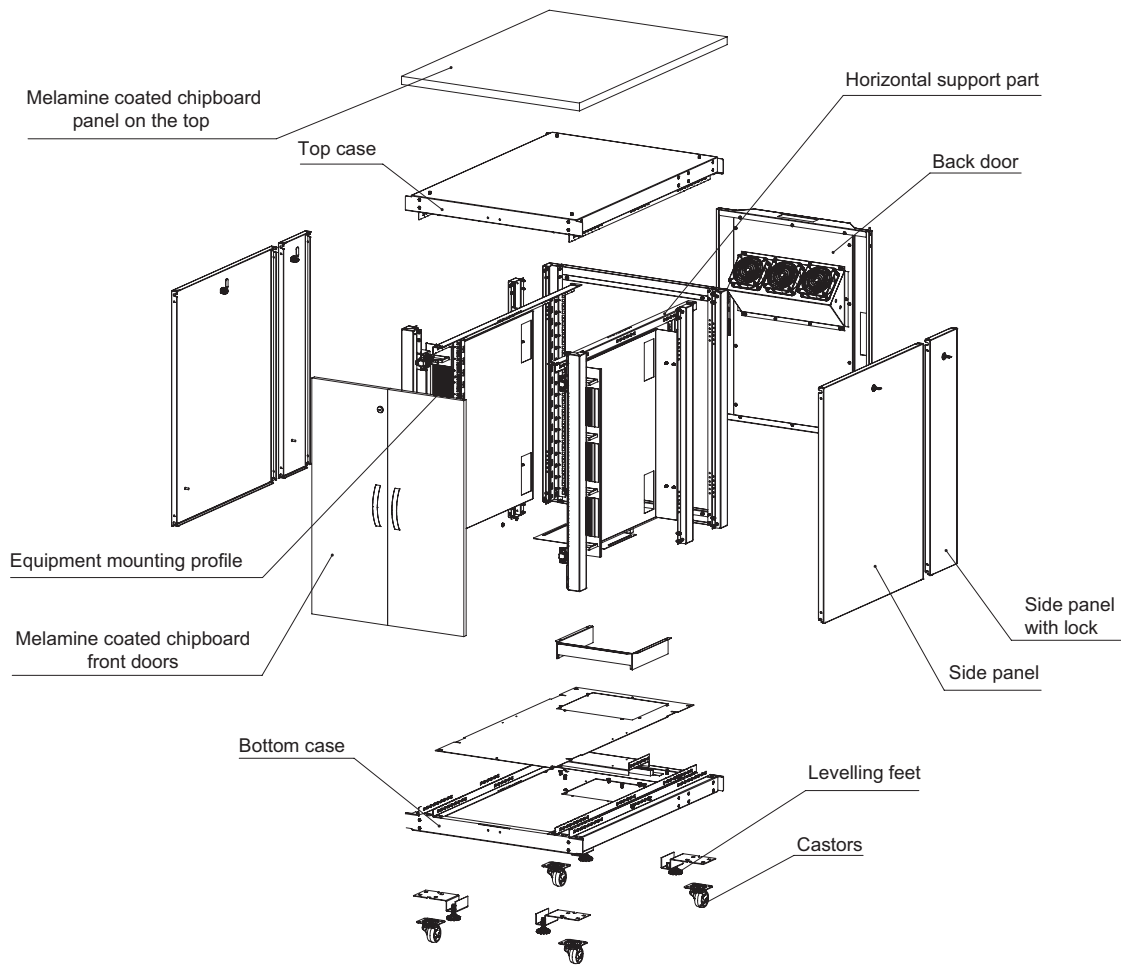

Exploded view

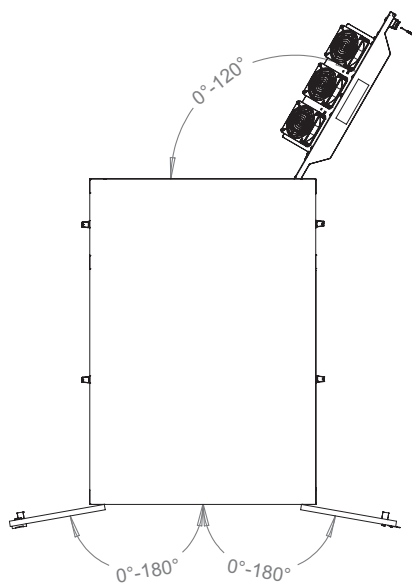

Front door opening angle

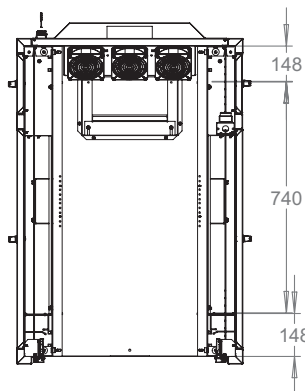

Equipment mounting distance

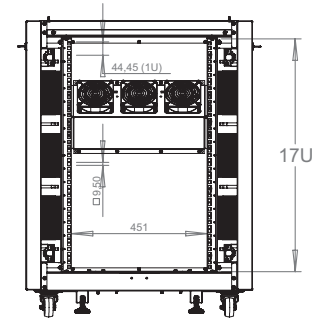

Dimensions in width and height

19" SOUNDproof

Free Standing Cabinets 17U

Construction Drawings

Width: 750 mm
Depth: 1130 mm

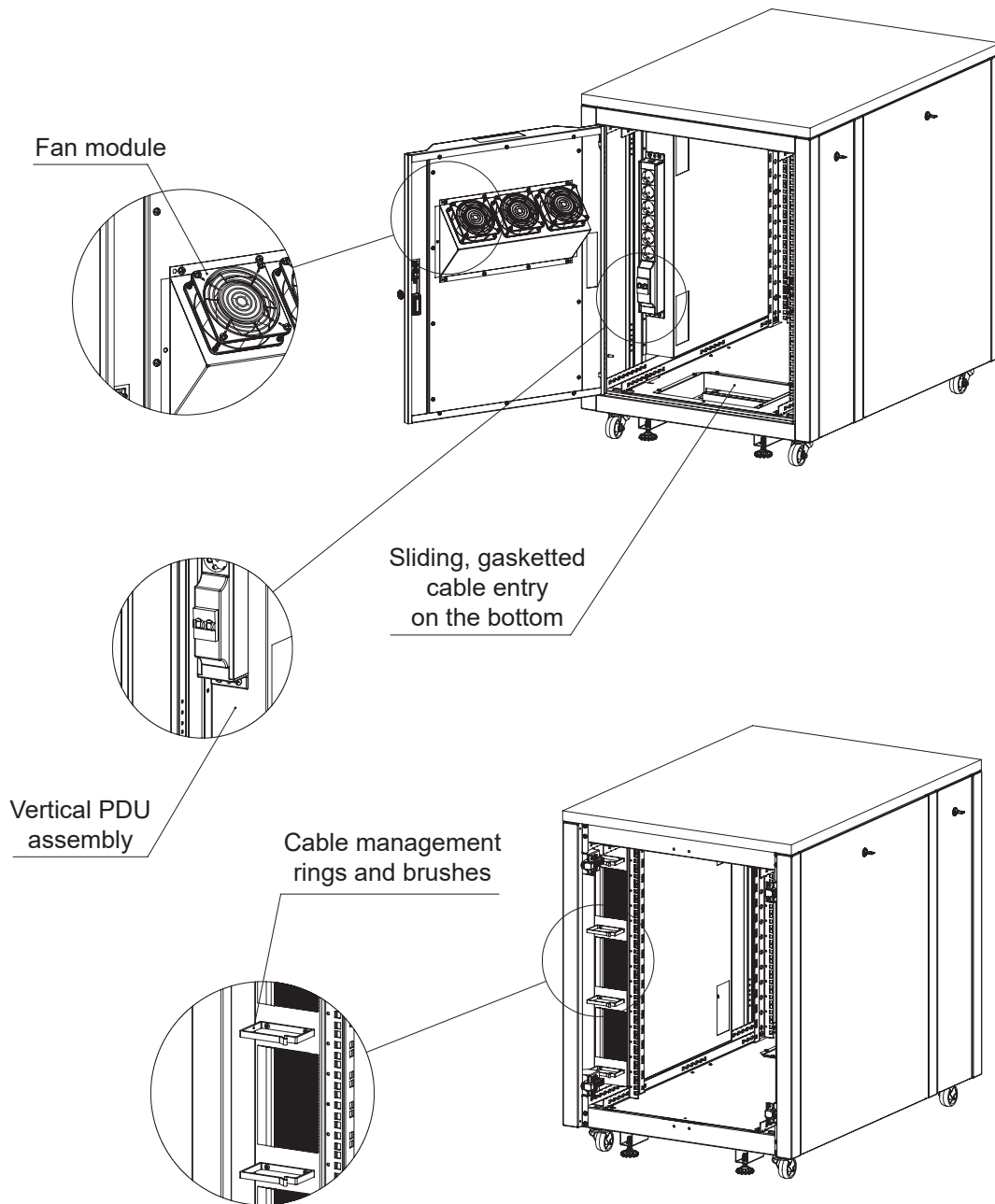

SOUNDproof Series Free Standing 19" Cabinets 17U W=750 mm D=1130 mm

Product Number	Product Description	Size WxDxH mm	h Size in U	h in mm	H mm, Overall Incl. Feet, Castor	Width Overall mm	Width Rail to Rail	Depth Overall mm	Depth Shipping Conf. Rail to Rail mm	QTY IN PACKAGE	PACKING DIMENSIONS WxDxH mm	Standard NET Weight of Product kg.	QTY IN PALETTE
LN-SP-17U7511-M-BL	17U 19" SOUNDproof Cabinet W=750 mm D=1130 mm	750x1130x1000	17U	756	1000	750	19"	1130	740	1	820x1200x1120	124	1

* Standard supply is with M-Maple Wood/Furniture Concept

** Incase requested with any other Wood/Furniture Concept, replace M with, C-Cherry, S-Black based on your selection.

*** All Metallic Parts are in RAL 9005 Black Color, any other color requests, please have a correspondence.



19" SOUNDproof Free Standing Cabinets

U Height: 32U

Width: 750 mm
Depth: 1130 mm

Static Load Capacity: 1500 kg.

Dynamic Load Capacity: 750 kg.
(on castors)

U Height: 32U

Standards and Compliances:



ISO 9001
Quality Management System

EN 61587-1
Mechanical Structures for
Electronic Equipment

EN IEC 60297, 19" Mounting
EN IEC 60917 Overall Cabinet
Dimensions

EN/IEC 60529 - IP20 Ingress Protection
performance

EIA/ ECA-310 (D/E) 19" 482,6 mm and
U 44,45 mm Height Sizing

TS EN ISO 11546 - Acoustic Test



CE conform to
EN 60950-1
Information Technology
Equipment-Safety-Part-1-
General Requirement



UL listed to
UL 2416, Outline of Investigation for
Audio/Video, Information and
Communication Technology Equipment
Cabinet, Enclosure and Rack
Systems; UL 60950-1 and CSA C22.2
NO. 60950-1-07, Information Technology
Equipment Safety
Part 1: General Requirements



Environment Friendly;
ISO 14001 Environmental
Management System
RoHS compliancy
%100 Recyclable Material



ISO 45001
The Occupational Health and Safety
Management System

Standard Color of Metal Parts:

E RAL 9005 Black

SOUNDproof free standing cabinets, with 19" w:750 mm
and d:1130 mm physical sizes, with max internal usable
depth 32U.



19" SOUNDproof

Free Standing Cabinets 32U

Construction Drawings

Width: 750 mm
Depth: 1130 mm

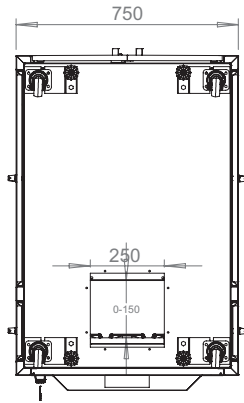

Bottom view

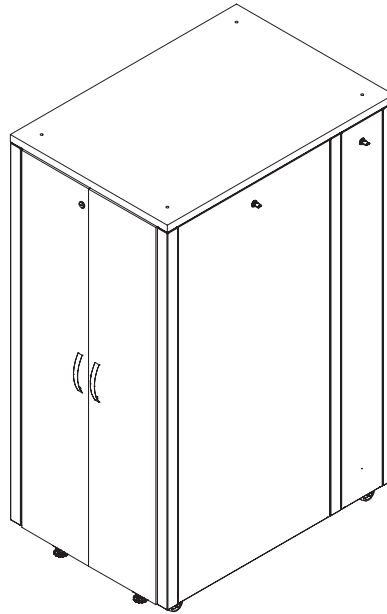

Isometric view

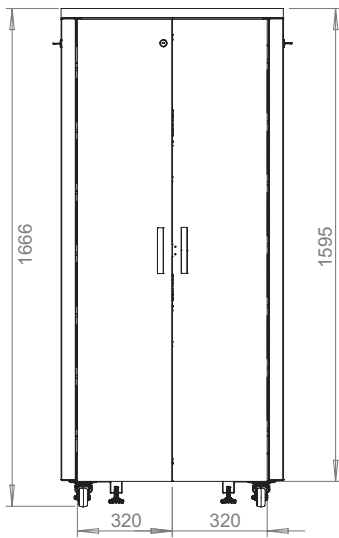

Front view

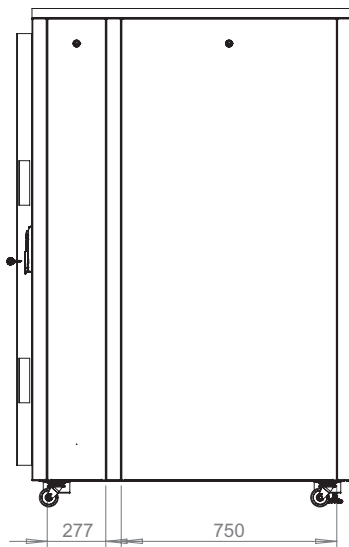

Side view

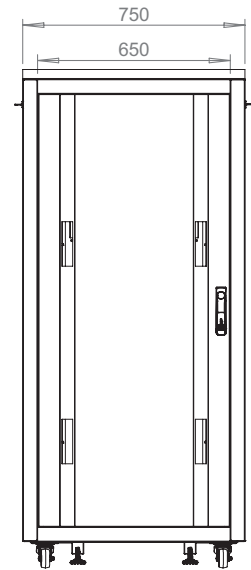

Rear view

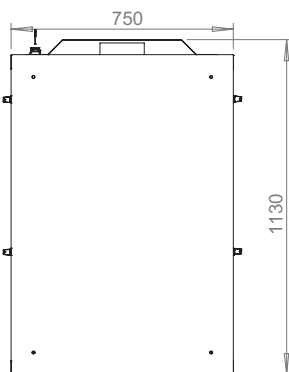

Top view

19" SOUNDproof

Free Standing Cabinets 32U

Construction Drawings

Width: 750 mm
Depth: 1130 mm

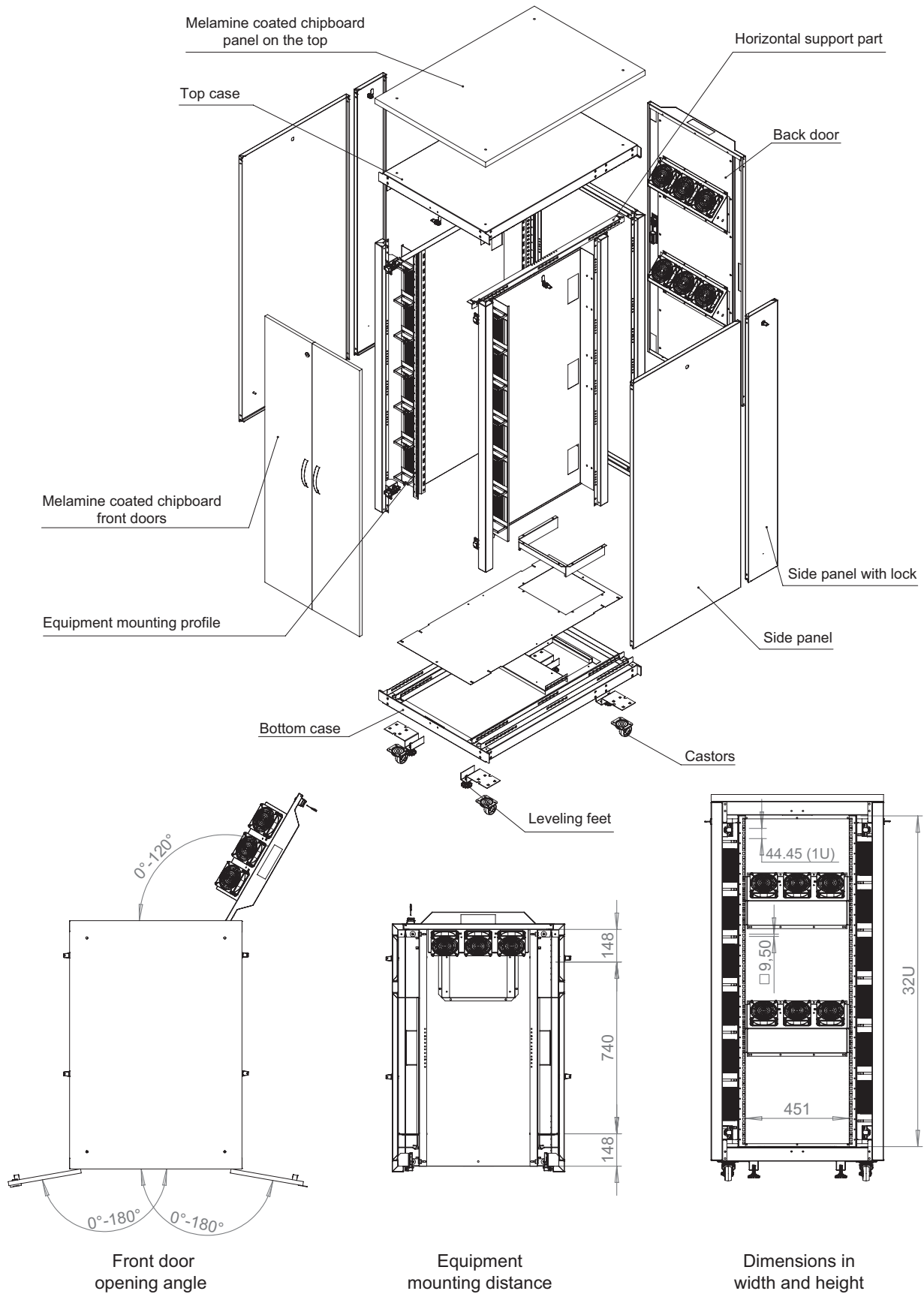

19" SOUNDproof

Free Standing Cabinets 32U

Construction Drawings

Width: 750 mm
Depth: 1130 mm

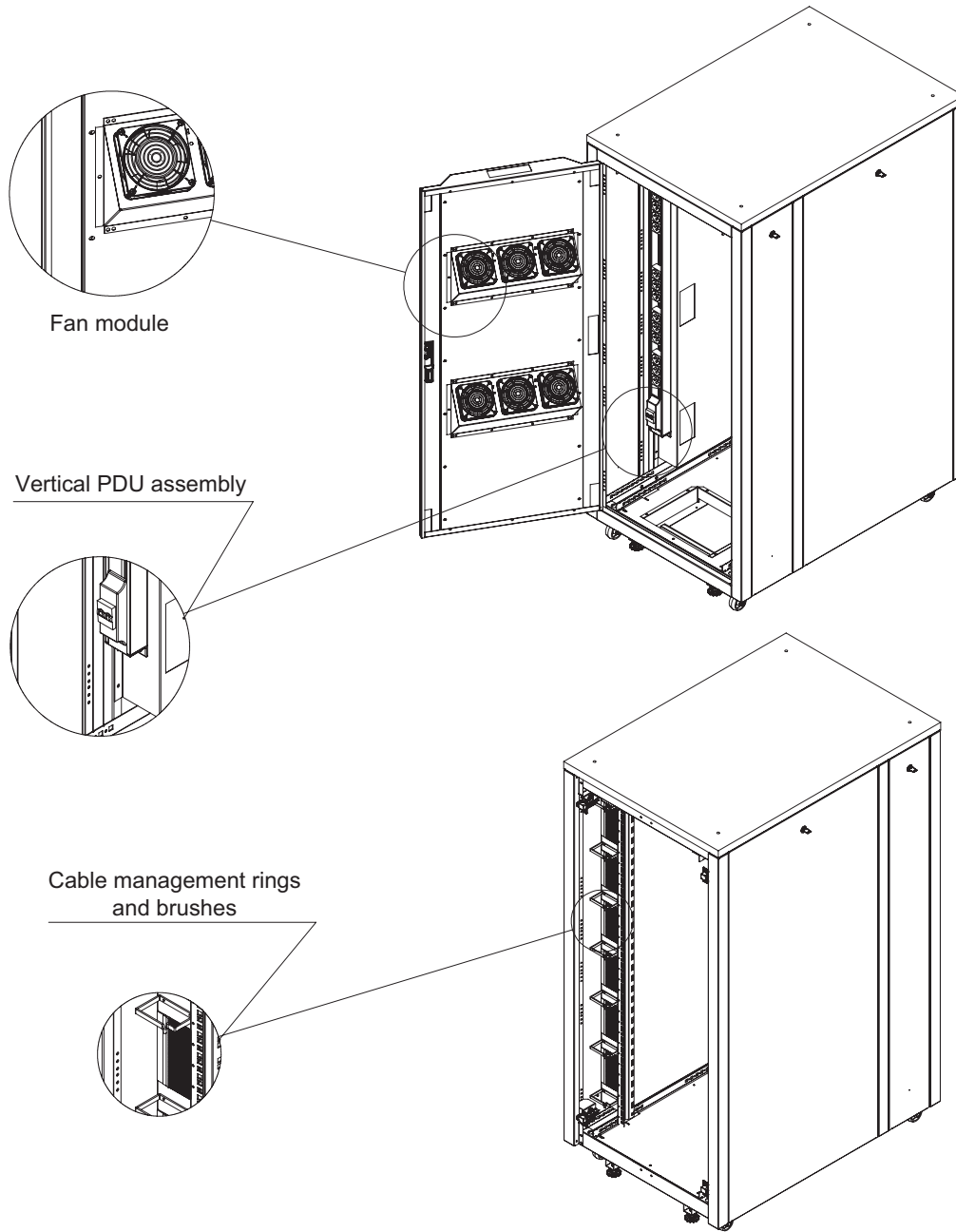

SOUNDproof Series Free Standing 19" Cabinets 32U W=750 mm D=1130 mm

Product Number	Product Description	Size WxDxH mm	h Size in U	h in mm	H mm, Overall Incl Feet, Castor	Width Overall mm	Width Rail to Rail	Depth Overall mm	Depth Shipping Conf. Rail to Rail mm	QTY IN PACKAGE	PACKING DIMENSIONS WxDxH mm	Standard NET Weight of Product kg.	QTY IN PALETTE
LN-SP-32U7511-M-BL	32U 19" SOUNDproof Cabinet W=750 mm D=1130 mm	750x1130x1666	32U	1423	1666	750	19"	1130	740	1	820x1200x1787	171	1

* Standard supply is with M-Maple Wood/Furniture Concept

** Incase requested with any other Wood/Furniture Concept, replace M with, C-Cherry, S-Black based on your selection.

*** All Metallic Parts are in RAL 9005 Black Color, any other color requests, please have a correspondence.



19" SOUNDproof Free Standing Cabinets

U Heights: 42U

Width: 750 mm
Depth: 1130 mm

Static Load Capacity: 1500 kg.

Dynamic Load Capacity: 750 kg.
(on castors)

U Height: 42U

Standards and Compliances:



ISO 9001
Quality Management System

EN 61587-1
Mechanical Structures for
Electronic Equipment

EN IEC 60297, 19" Mounting
EN IEC 60917 Overall Cabinet
Dimensions

EN/IEC 60529 - IP20 Ingress Protection
performance

EIA/ ECA-310 (D/E) 19" 482,6 mm and
U 44,45 mm Height Sizing

TS EN ISO 11546 - Acoustic Test



CE conform to
EN 60950-1
Information Technology
Equipment-Safety-Part-1-
General Requirement



UL listed to
UL 2416, Outline of Investigation for
Audio/Video, Information and
Communication Technology Equipment
Cabinet, Enclosure and Rack
Systems; UL 60950-1 and CSA C22.2
NO. 60950-1-07, Information Technology
Equipment Safety
Part 1: General Requirements



Environment Friendly;
ISO 14001 Environmental
Management System
RoHS compliancy
%100 Recyclable Material



ISO 45001
The Occupational Health and Safety
Management System

Standard Color of Metal Parts:



RAL 9005 Black

SOUNDproof free standing cabinets, with 19" w:750 mm
and d:1130 mm physical sizes, with max internal usable
depth 42U.



19" SOUNDproof

Free Standing Cabinets 42U

Construction Drawings

Width: 750 mm
Depth: 1130 mm

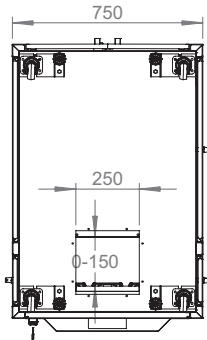

Bottom view

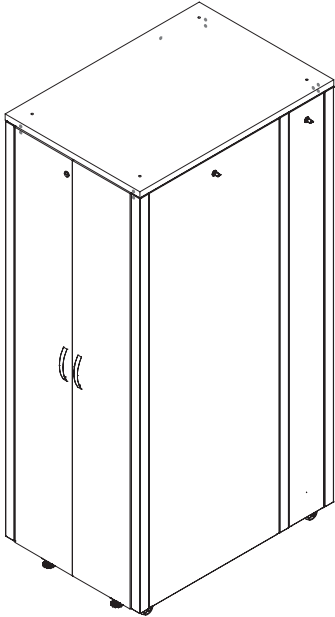

Isometric view

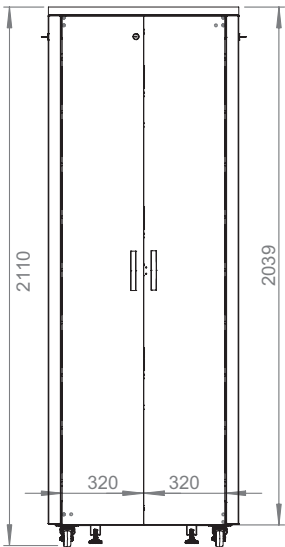

Front view

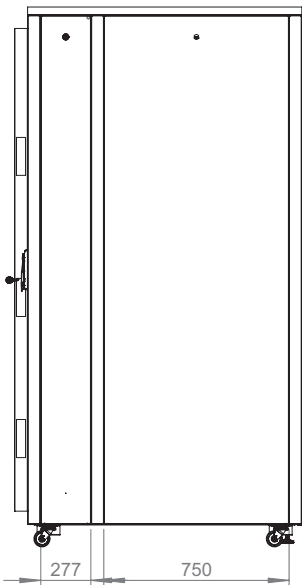

Side view

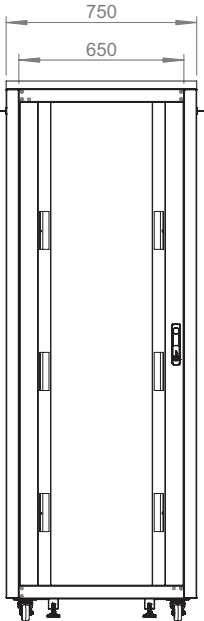

Rear view

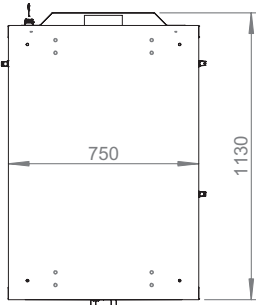

Top view

19" SOUNDproof

Free Standing Cabinets 42U

Construction Drawings

Width: 750 mm
Depth: 1130 mm

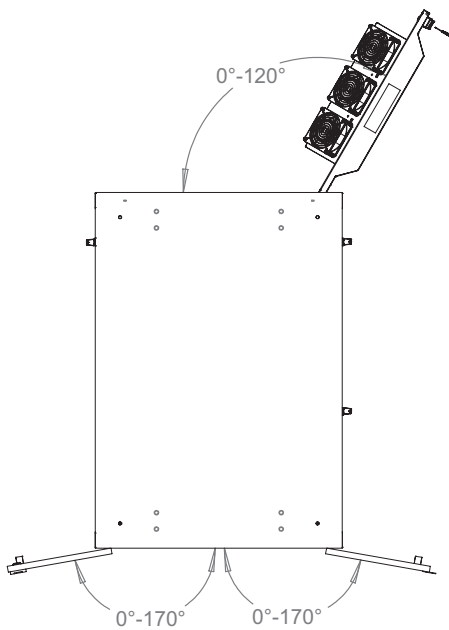
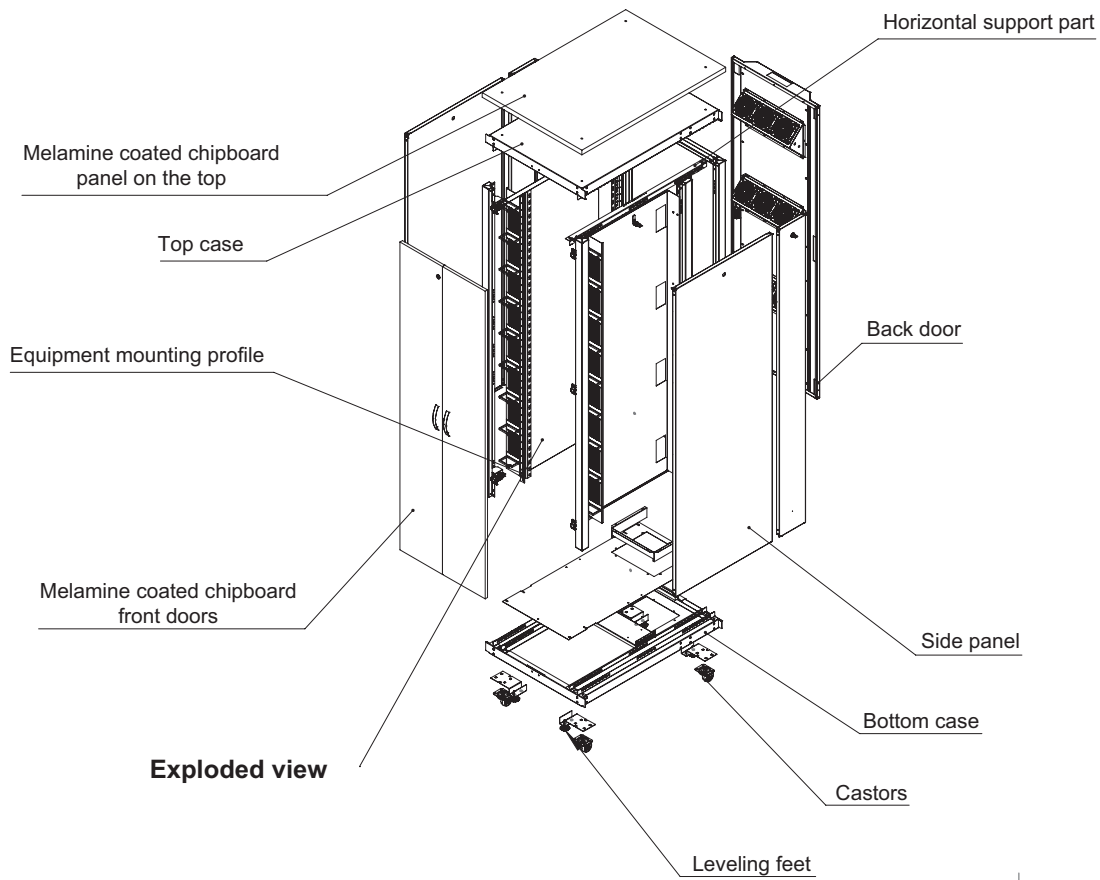

Front door opening angle

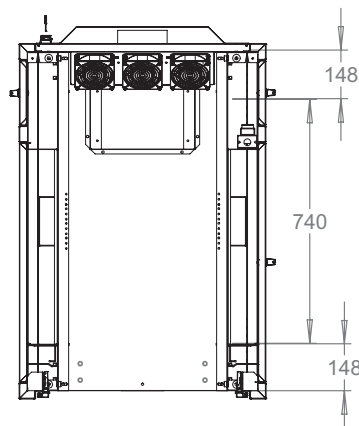

Equipment mounting distance

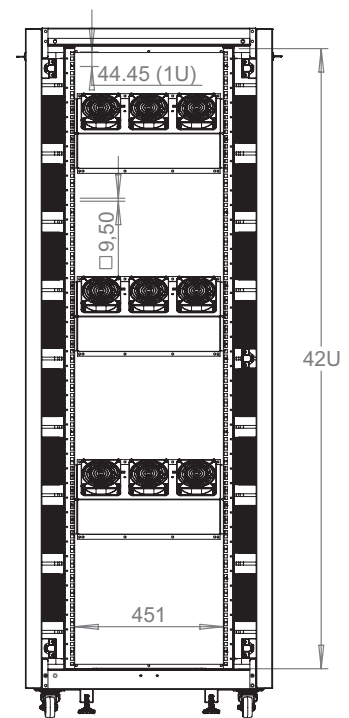

Dimensions in width and height

19" SOUNDproof

Free Standing Cabinets 42U

Construction Drawings

Width: 750 mm
Depth: 1130 mm

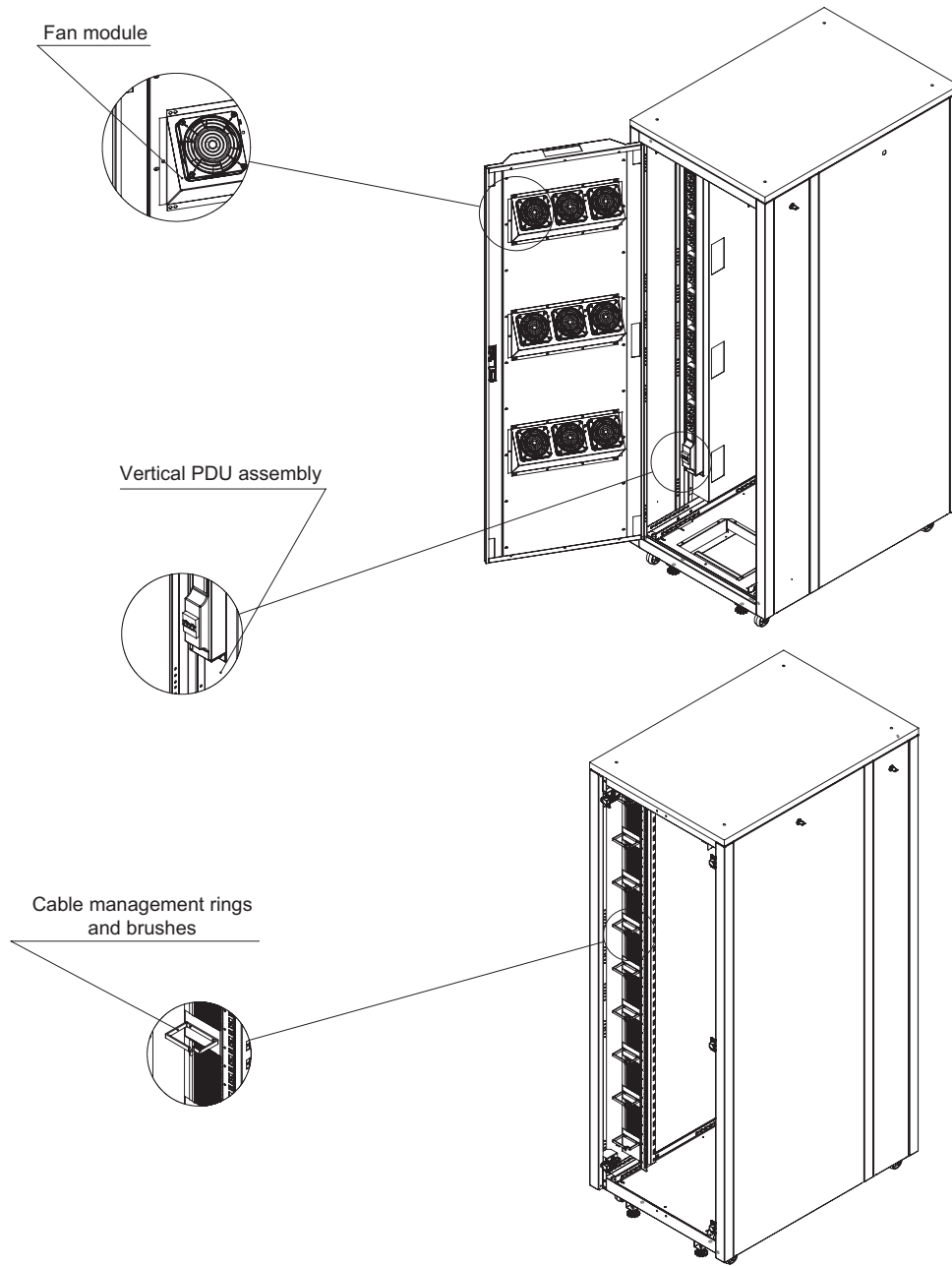

SOUNDproof Series Free Standing 19" Cabinets 42U W=750 mm D=1130 mm

Product Number	Product Description	Size WxDxH mm	h Size in U	h in mm	H mm, Overall Incl Feet, Castor	Width Overall mm	Width Rail to Rail	Depth Overall mm	Depth Shipping Conf. Rail to Rail mm	QTY IN PACKAGE	PACKING DIMENSIONS WxDxH mm	Standard NET Weight of Product kg.	QTY IN PALETTE
LN-SP-42U7511-M-BL	42U 19" SOUNDproof Cabinet W=750 mm D=1130 mm	750x1130x2110	42U	1867	2110	750	19"	1130	740	1	820x1200x2231	198	1

* Standard supply is with M-Maple Wood/Furniture Concept

** Incase requested with any other Wood/Furniture Concept, replace M with, C-Cherry, S-Black based on your selection.

*** All Metallic Parts are in RAL 9005 Black Color, any other color requests, please have a correspondence.



19" SOUNDproof

Free Standing Cabinets

Accessories

Fixed shelves universal mutivendor	17U	32U	42U
	LN-RAF-SBT-D100-BL-UNV	LN-RAF-SBT-D100-BL-UNV	LN-RAF-SBT-D100-BL-UNV



Heavy duty fixed shelves	17U	32U	42U
	LN-RAF-SBA-D100-BL	LN-RAF-SBA-D100-BL	LN-RAF-SBA-D100-BL

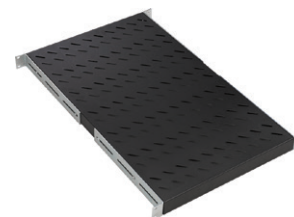

Heavy duty sliding shelves	17U	32U	42U
	LN-RAF-HRA-D100-BL	LN-RAF-HRA-D100-BL	LN-RAF-HRA-D100-BL

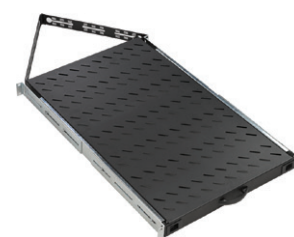

Horizontal cable management panel 19" 1U 5 rings	17U	32U	42U
	LN-KDG-YKD-1UKN-BL	LN-KDG-YKD-1UKN-BL	LN-KDG-YKD-1UKN-BL



Mounting hardware, fixing M6 cage nut set of 20	17U	32U	42U
	LN-DGR-KFS-M620-XX	LN-DGR-KFS-M620-XX	LN-DGR-KFS-M620-XX



	17U	32U	42U
Fan modules max 30dB low noise with thermostat	3 Fans with thermostat included in shipping	6 fans with thermostat included in shipping	9 fans with thermostat included in shipping
Castor set	Included	Included	Included
Leveling feet group	Included	Included	Included
Cable management panel and rings	Included	Included	Included



*** There are various type other accessories can be integrated to Soundproof Cabinets, please see various model compatible rack mount accessories in main catalogue accessories section.

19" SOUNDproof

Free Standing Cabinets

Accessories



6xDIN49440 socket schuko power stripe, 19" 1U, aluminium housing, 1x16A cct breaker, 4000 Watt, 250V AC, 3x1.5 mm², 2,5m cable, DIN 49441 plug, CE approval

	17U	32U	42U
	LN-PRZ-SGT-1U6P-SC	LN-PRZ-SGT-1U6P-SC	LN-PRZ-SGT-1U6P-SC



6xIEC 320 C13 socket power stripe, 19" aluminium housing, 1x16A cct breaker, 4000 watt, 250V AC, 2,5 m cable, DIN 49441 plug, CE approval

	17U	32U	42U
	LN-PRZ-SGT-1U6P-IE	LN-PRZ-SGT-1U6P-IE	LN-PRZ-SGT-1U6P-IE

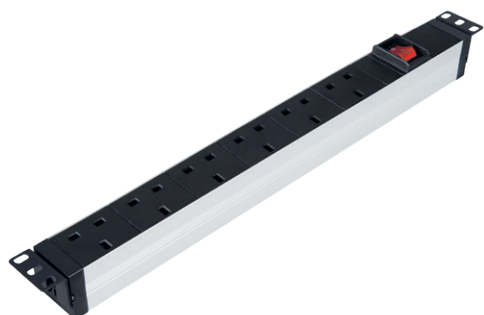

6xBS1363 UK socket power stripe, 19" 1U, aluminium housing, lighted on/off switched, 13A 3250 watt, 250V AC, 3x1.5 mm², 2,5m cable, 13A BS1363 plug, CE mark

	17U	32U	42U
	LN-PRZ-ONF-1U6P-UK	LN-PRZ-ONF-1U6P-UK	LN-PRZ-ONF-1U6P-UK



6xDIN49440 socket schuko surge protection power stripe, 19" 1U, aluminium housing, 16A lighted on/off switched, 4000 watt, 250V AC, 3x1.5 mm², 2,5m cable, DIN 49441 plug, CE approval

	17U	32U	42U
	LN-PRZ-AKK-1U6P-SC	LN-PRZ-AKK-1U6P-SC	LN-PRZ-AKK-1U6P-SC



6xIEC 320 C13 socket PDU with ampermeter display, 19" 1U, aluminium profile frame, 1x16A MCB, 4000 Watt, 250V AC, 3x2.5 mm², 3m cord with IEC60309 plug (16A 2P+E), CE mark

	17U	32U	42U
	LN-PRZ-AMP-1U6P-IE	LN-PRZ-AMP-1U6P-IE	LN-PRZ-AMP-1U6P-IE

19" SOUNDproof

Free Standing Cabinets

Accessories / Basic Power Distribution Units (PDU, Vertical)



	17U	32U	42U
12xDIN49440 socket schuko power stripe - double circuit (9+9), aluminium housing, 2pcs. 1x16A cct breaker, 250vac, for 17U cabinet height, no cable, ready cable connection point	LN-PRZ-SGT-1712-SC (max 2 pcs)	-	-
12xIEC 320 C13 socket power stripe - double circuit (9+9), aluminium housing, 2pcs. 1x16A cct breaker, 250vac, for 17U cabinet height, no cable, ready cable connection point	N-PRZ-SGT-1712-IE (max 2 pcs)	-	-
16xDIN49440 socket schuko power stripe - double circuit (9+9), aluminium housing, 2pcs. 1x16A cct breaker, 250vac, for 32U cabinet height, no cable, ready cable connection point	-	LN-PRZ-SGT-3216-SC (max 2 pcs)	-
16xIEC 320 C13 socket power stripe - double circuit (9+9), aluminium housing, 2pcs. 1x16A cct breaker, 250vac, for 32U cabinet height, no cable, ready cable connection point	-	LN-PRZ-SGT-3216-IE (max 2 pcs)	-
18xDIN49440 socket schuko power stripe - double circuit (9+9), aluminium housing, 2pcs. 1x16A cct breaker, 250vac, for 42U cabinet height, no cable, ready cable connection point	-	-	LN-PRZ-SGT-4218-SC (max 2 pcs)
18xIEC 320 C13 socket power stripe - double circuit (9+9), aluminium housing, 2pcs. 1x16A cct breaker, 250vac, for 42U cabinet height, no cable, ready cable connection point	-	-	N-PRZ-SGT-4218-IE (max 2 pcs)

19" SOUNDproof

Free Standing Cabinets

Accessories / Power Distribution Units (PDU, vertical)

Monitoring and Managed Intelligent

IEC 320 C13
lockable and
C19 socket
combinations

Hydraulic magnetic
circuit breakers



<p>24xIEC 320 (20xC13 + 4xC19) socket, MONITORED IP PDU with LCD display, ZeroU, metal body, 2pcs 1P 16A hydraulic circuit breaker, 8000 Watt, 250V AC, 3x6.0 mm², 3m cord with IEC60309 plug (32A 2P+E) ,CE mark, daisy-chain function up to 1 master 4 slave units, remote monitoring port- PDU based monitoring</p>
<p>42xIEC 320 (36xC13 + 6xC19) socket, MONITORED IP PDU with LCD display, ZeroU, metal body, 2pcs 1P 16A hydraulic circuit breaker, 8000 Watt, 250V AC, 3x6.0 mm², 3m cord with IEC60309 plug (32A 2P+E) ,CE mark, daisy-chain function up to 1 master 4 slave units, remote monitoring port- PDU based monitoring</p>
<p>24xIEC 320 (20xC13 + 4xC19) socket, MANAGED IP PDU with LCD display, ZeroU, metal body, 2pcs 1P 16A hydraulic circuit breaker, 8000 Watt, 250V AC, 3x6.0 mm², 3m cord with IEC60309 plug (32A 2P+E) ,CE mark, daisy-chain function up to 1 master 4 slave units, remote monitoring port- outlet based monitoring and remote switch on/off function per socket or group of sockets</p>

	17U	32U	42U
	-	-	LN-PRZ-IZP-DM24-IE
	-	-	LN-PRZ-IZP-DM42-IE
	-	-	LN-PRZ-YNP-DM24-IE

Main functions	Product series	
	IZP series	YNP series
Accurate measurement of total energy consumption	✓	✓
Total working voltage metering	✓	✓
Total load current metering	✓	✓
Total power metering	✓	✓
Power factor monitoring	✓	✓
Temperature & humidity monitoring	✓	✓
Outlet current metering		✓
Outlet power metering		✓
Threshold setting of outlet current		✓
Accurate measurement of outlet energy consumption		✓
Outlet switching		✓
Delay setting of outlet sequential switching		✓



- LCD DISPLAY:** Display electrical parameters like Amp, volt, kW, kWh, power factor etc.
- NET:** For Ethernet access (Http/Https), support remote data backup.
- SER:** For serial access, MODBUS protocol.
- USB:** For WIFI access and kernel update.
- SENSÖR:** To connect external sensor extension box which has 2 temperature & humidity sensor port, 2 door sensor port, 1 water sensor port and 1 smoke sensor port.



19" SOUNDproof

Free Standing Cabinets

Accessories / Basic Power Distribution Units (PDU, vertical)
with Ampermeter Display Unit

Lockable sockets



IEC 320 C13
lockable and
C19 socket
combinations

Multimeter display



Optional
Accessory

24xIEC 320 (20xC13 + 4xC19) socket PDU with multimeter display, ZeroU, aluminium profile frame, 2x16A MCB, 8000 Watt, 250V AC, 3x6.0mm², 3m cord with IEC 60309 plug (32A 2P+E), CE mark, locking on sockets standard on both C13 and C19. Along with multimeter display other metering functions are added, V, A, W, kW, PF, temperature probe and sensing, total operating time.

17U

32U

42U

-

LN-PRZ-AMP-DM24-IE

LN-PRZ-AMP-DM24-IE

19" SOUNDproof Cabinet Acoustic Test TS EN ISO 11546 Standard

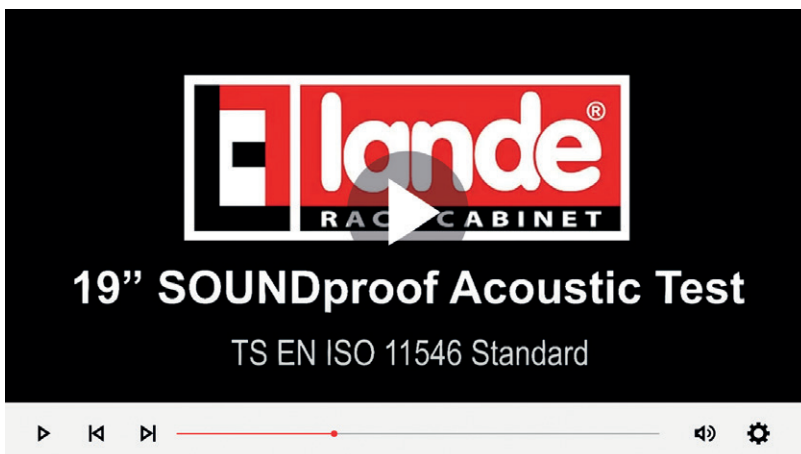

<https://youtu.be/HFxt2I8I9mM>



CONTACT DETAILS

Headquarters

Address:

Merve Mah. Gazi Cad.
No: 17 34791 Sancaktepe
İstanbul / TÜRKİYE

Phone: +90 216 312 26 53

Fax : +90 216 312 09 09

Factory

Address:

20. Cadde No: 14 Eskişehir
Organize San. Bölğ. 26250
Eskişehir / TÜRKİYE

Phone: +90 222 236 24 66 pbx

Fax : +90 222 236 13 53

www.lande.com.tr | sales@lande.com.tr

