



Glensound



GS- MPI005HD MKII

**HD Voice Broadcaster's Mobile Phone
subrack**

PRODUCT DETAILS





GlenSound Electronics Ltd

Thank you for choosing a new GlenSound product.

All rights reserved.

Information contained in this manual is subject to change without notice, if in doubt please contact us for the latest product information.

If you need any help with the product then we can be contacted at:

GlenSound Electronics Ltd
1 – 6 Brooks Place
Maidstone
Kent
ME14 1HE
United Kingdom

Telephone: +44 (0) 1622 753662

Fax: +44 (0) 1622 762330

EMAIL ADDRESSES

General enquires: office@glenSound.co.uk

Technical enquires: techinfo@glenSound.co.uk

Sales enquires: sales@glenSound.co.uk

PRODUCT WARRANTY

All equipment is fully tested before dispatch and carefully designed to provide you with trouble free use for many years.

We have a policy of supporting products for as long as possible and guarantee to be able to support your product for a minimum of 10 years.

For a period of one year after the goods have been despatched the Company will guarantee the goods against any defect developing after proper use providing such defects arise solely from faulty materials or workmanship and that the Customer shall return the goods to the Company's works or their local dealer.

All non-wear parts are guaranteed for 2 years after despatch and any defect developing after proper use from faulty materials or workmanship will be repaired under this warranty providing the Customer returns the goods to the Company's works or their local dealer.



SAFETY WARNING



This product can produce high sound levels via the headphone output.

Please take caution when operating this product as listening to excessively high peak or sustained levels of volume may permanently damage human hearing.

IMPORTANT SAFETY INSTRUCTIONS

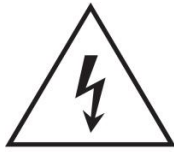

This symbol is intended to warn that dangerous voltages within the product are present and constitute a risk of electric shock.



This symbol is intended to highlight that there are important operating & maintenance instructions in the literature accompanying this unit.

- 1) Read these instructions
- 2) Keep these instructions
- 3) Heed all warnings
- 4) Follow all instructions
- 5) Do not use this apparatus near water
- 6) Clean only with a dry cloth
- 7) Do not block any ventilation openings. Install in accordance with manufacturer's instructions
- 8) Do not install near any heat sources such as radiators, heat registers, stoves, or other apparatus (including amplifiers) that produce heat
- 9) Do not defeat the safety purpose of the polarized or grounding type plug. A polarized plug has 2 blades with one wider than the other. A grounding type plug has 2 blades and third grounding prong. The wider blade or the 3rd prong are provided for your safety. If the provided plug does not fit into your outlet, consult an electrician for replacement of the obsolete outlet
- 10) Protect the power cord from being walked on or pinched, particularly at plugs, convenience receptacles and the point where they exit from the apparatus
- 11) Only use attachments/ accessories specified/ supplied by the manufacturer
- 12) Use only with the cart, stand, tripod, bracket, or table specified by the manufacturer, or sold with the apparatus. When a cart is used, use caution when moving the cart/ apparatus combination to avoid injury from tip over
- 13) Unplug this apparatus during lightning storms or when unused for long periods of time
- 14) Refer all servicing to qualified service personnel. Servicing is required when the apparatus has been damaged in any way, such as power supply cord or plug is damaged, liquid has been spilled or objects have fallen into the apparatus, the apparatus has been exposed to rain or moisture, does not operate normally, or has been dropped
- 15) Do not attempt to modify this product. Doing so could result in personal injury and/ or product failure



CAUTION

RISK OF ELECTRICAL SHOCK
DO NOT OPEN



CAUTION: TO REDUCE THE RISK OF ELECTRIC SHOCK,
DO NOT REMOVE COVER (OR BACK) .
NO USER-SERVICABLE PARTS INSIDE.
REFER TO SERVICING TO QUALIFIED PERSONNEL.

WARNING:

To reduce the risk of fire or electric shock, do not expose this product to rain or moisture.



EU DECLARATION OF CONFORMITY

GS-MPI005HD MKII

HD Voice Mobile Phone Rack

This declaration of conformity is issued under the sole responsibility of the manufacturer.

This equipment is manufactured by Glensound Electronics Ltd of Brooks Place Maidstone Kent ME14 1HE is  marked and conforms to the following Union harmonisation legislation:

Emissions:	BS EN55032:2015
Immunity:	BS EN55035:2017

Signed for and on behalf of Glensound Electronics Ltd.

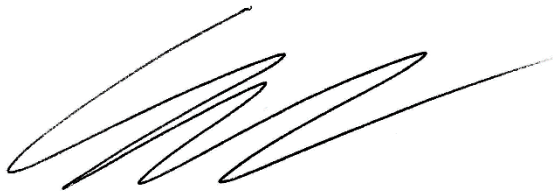

Gavin Davis, Managing Director
Maidstone, Kent, England

Date: 12/11/2018

RoHS DIRECTIVE

RoHS 2 Directive 2011/65/EU restricts the use of the hazardous substances listed below in electrical and electronic equipment.

This product conforms to the above directive and for these purposes, the maximum concentration values of the restricted substances by weight in homogenous materials are:

Lead	0.1%
Mercury	0.1%
Hexavalent Chromium	0.1%
Polybrominated Biphenyls	0.1%
Polybrominated Diphenyl Ethers	0.1%
Cadmium	0.01%

WASTE ELECTRICAL AND ELECTRONIC EQUIPMENT REGULATIONS 2006 (WEEE)

GlenSound Electronics Ltd is registered for business to business sales of WEEE in the UK our registration number is:

WEE/JJ0074UR

CONFORMITY STATEMENT FOR:

Gemalto Module PLS8-E

to which this declaration relates, is in conformity with the following standards and/or other normative documents, by specific reference to the essential requirements of Radio Equipment Directive 2014/53/EU:

Health and Safety	EN 60950-1 :2006+A11 :2009+A1 :2010 +A12:2011+A2:2013; EN 62311 :2008
EMC	draft EN 307 489-1:v2.2.0; draft EN 301 489-19:v2.7.0; draft EN 301 489-52:v7.1.0
RF spectrum efficiency	EN 301 577:v12.5.7; EN 303 413:vl.1.7; EN 301 908- 1:vll.1.1; EN 301 908-2:vll.1.2; EN 301 908-13:vll.1.2

Gemalto Module PLS8-US R4

to which this declaration relates, is in conformity with the following standards and/or other normative documents, by specific reference to the essential requirements of Radio Equipment Directive 2014/53/EU:

Health and Safety	EN 60950-1 :2006+A1 1 :2009+A7 :207 0+A1 2:2017 +A2:201 3; EN 62311:2008
EMC	draft EN 307 489-1:v2.2.0; draft EN 301 489-19:v2.7.0; draft EN 307 489-52:vl.1.0
RF spectrum efficiency	EN 301 511:v12.5.7; EN 303 473:vl.1.1; EN 301 908- l:vll.7.1; EN 301 908-2:vll.1.2; EN 307 908-73:vll.1.2

GLENSOUND GS-MPI005HD MKII

HANDBOOK CONTENTS

Issue 3

Description

Page No.

Contents

PRODUCT WARRANTY	3
EU DECLARATION OF CONFORMITY	5
RoHS DIRECTIVE	6
WASTE ELECTRICAL AND ELECTRONIC EQUIPMENT REGULATIONS 2006 (WEEE).....	6
CONFORMITY STATEMENT FOR:	7
Gemalto Module PLS8-E.....	7
Gemalto Module PLS8-US R4	7
HANDBOOK CONTENTS.....	8
OVERVIEW	10
FRONT PANEL LAYOUT.....	11
REAR PANEL LAYOUT	13
MAKING A CALL.....	15
Using the Touchscreen.....	15
Using the Optional Handset Interface	16
ANSWERING A CALL.....	16
Using the Touchscreen.....	16
Using the Optional Handset Interface	16
DIVERTING/ TRANSFERRING A CALL BETWEEN THE HANDSET & XLRs.....	17
SENDING DTMF TO THE LINE.....	19
Using the Touchscreen.....	19
Using the Handset	19
USING THE TOUCHSCREEN/ MENUS.....	20
Home Screen.....	20
Mobile Icon	21
Contacts Icon.....	22
Adding a Contact	23
The Settings Icon.....	24
Network Settings Options	25
Display Settings.....	26
Sound Settings	27
Auto answer enable.....	28
Call transfers divert to Dante only NOT handset.....	28
MAC Address	28
About	29
Output Levels	30

GPIO Menu.....	31
Headphone Menu	34
WEB CONTROL INTERFACE	35
Configuring the device for web access.....	35
Connecting to the device	36
Using the web interface	36
OPTIONAL DANTE®/ AES67 NETWORK INTERFACE	37
Dante Circuit Names	37
Getting Dante Controller.....	38
Connecting GS-MPI005HD MKII To the Network	38
Audio Over IP Network.....	38
Running Dante Controller	39
Dante Controller TIP	39
Device Not Showing Up In Dante Controller	40
AES67 MODE	41
Turning On AES67 Mode	41
Sending AES67 Audio	42
Receiving AES67 Audio	43
AES67 Restrictions.....	43
UPDATING FIRMWARE	44
Equipment needed	44
Instructions	44
UPDATING THE ULTIMO CHIPSET	49
Finding Out Current Installed Version	49
Finding Out What The Latest Available Version Is.....	49
Updating the device.....	49
WIRING INFORMATION.....	50
XLR & JACK Wiring.....	50
D9 Wiring & Loop Interconnecting To External Equipment	51
Handset Connector.....	52

OVERVIEW

The GS-MPI005HD MKII is a next generation mobile phone subrack designed for use in broadcast trucks and studios. It builds on previous generations of GS-MPI005 mobile phone subracks.

Each GS-MPI005HD MKII can be fitted with one or two phone modules each phone module can be either a 900MHz (European) or 850MHz (US) variant. Both versions work in other countries as well as 'Europe' and 'US' depending upon the cell phone network frequencies that are used by the telecom providers in the other country.

The mobile phone modules in the GS-MPI005HD MKII are unlocked mobile phones and will work with any sim cards from any providers.

One touchscreen display is mounted on the front of the GS-MPI005HD MKII for each mobile phone fitted. The touchscreen is a resistive touch version which requires a more determined 'push' when using than the capacitive touchscreens used on many modern mobile phones.

An external telephone handset can be connected to the GS-MPI005HD MKII for making/ answering calls and for using for off air conversations prior to passing the call to the analogue XLR circuits on the rear of the unit.

One external telephone handset is required for each phone module fitted.

The external telephone handsets are a useful feature of the unit but are not necessary for day to day operation as calls can be setup and made/ ended using the touchscreen display.

An optional Dante®/ AES67 network audio interface is available that provides 4 audio circuits (2 for each phone module) for interfacing to external network audio equipment.

The unit is mains powered by a wide range internal switch mode power supply which is terminated with a standard 3 pin IEC mains plug. Please note this unit must be earthed.

FRONT PANEL LAYOUT

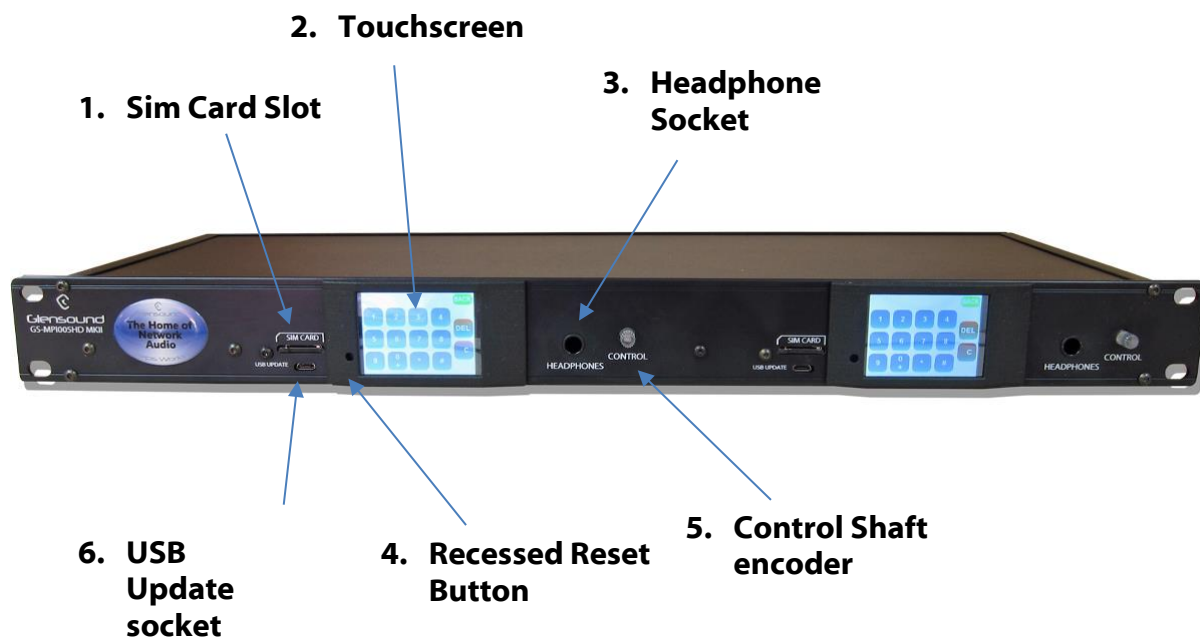

1. Sim Card Slot

The sim card slot accepts Micro sim cards. These should be inserted with the electrical contacts facing down.

When inserting the sim card it must be pushed slightly below the surface of the front panel before it will be held in place by the socket. Likewise when removing the sim card it must first be pushed slightly into the socket before the socket will release it and allow it to be extracted. A very quiet but audible click can be heard once the sim card has been pushed into the socket far enough to enable it to be fitted/ removed.

The sim card slot has deliberately been designed to force the sim card to have to be pushed slightly below the front panel surface to remove it to prevent it being accidentally removed.

2. Touchscreen

The colour touchscreen is used for accessing the menu system for setting up the unit in a way that is suitable for the end user. It can also be used for day to day operation of making/ ending calls.

The touchscreen is a resistive touch type. This means that it needs a slightly more firm push to operate than an average domestic mobile phone that uses a capacitive touchscreen.

Resistive touchscreens generally work well when operated by a stylus/ pen.

3. **Headphone Socket**

This 6.35mm (1/4") stereo (Tip Ring Sleeve) jack socket can be used for monitoring any of the phones audio sources.

In the settings menu it is possible to adjust the audio level of each of these sources into the headphone's mix circuit to suit the way that you want to work.

Headphone volume is adjusted by using the front panel 'Control Shaft Encoder' (see no 6).

The headphone amplifier uses one of our clever designs that allows both high and low impedance headphones to be connected without any degradation of signal and even allows mono earpieces to be connected without any damage to the circuit.

4. **USB Update Socket**

This is a micro USB socket.

It is used for updating the devices firmware (the software that runs on the internal microprocessors and makes it work).

5. **Recessed Reset Button**

This button should only ever be used if advised to by Glensound's technical support team.

The button itself is recessed about 13mm inside the unit and requires a straight narrow firm object (such as a straightened paper clip) to operate it. The head of the button is only about 3mm in diameter so the paper clip must be inserted level and straight to make contact.

When operated the button only moves about 1mm so if you are advised to use it please do not press too hard with the paper clip.

6. **Control Shaft Encoder**

This rotary shaft encoder can be turned and also pushed and used as a switch. It is illuminated and the colour is used to indicate different operational states.

In general day to day use the encoder can be turned and used to adjust the headphone volume.

If in a settings page with an adjustable level control (such as the display brightness setting or sound settings sounder volume control) then the encoder can be turned to adjust the settings value.

During normal day to day use the encoder is illuminated red to show that no call is in progress, it flashes green to show that there is an incoming call and steady green indicates that a call is in progress.

REAR PANEL LAYOUT

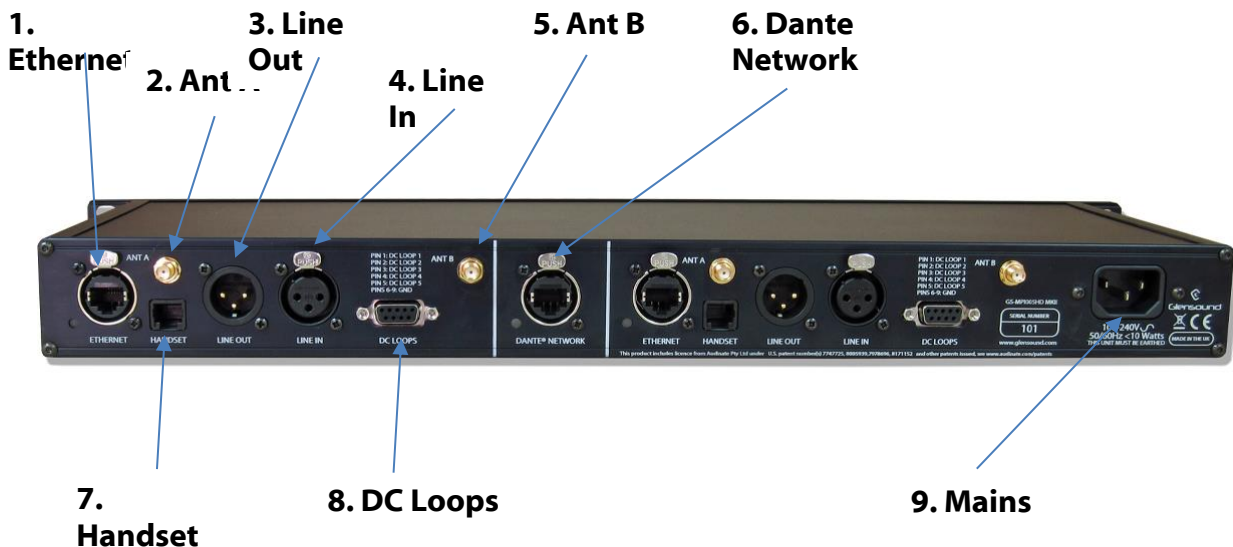

1. Ethernet Connector

The Ethernet connector is for remote control from a web browser on a computer connected to the same network as the MPI005HD MKII. For more information on using the web interface, go to [page 34](#).

The Ethernet control circuit has been deliberately kept separate to the network audio circuit (no 6).

2. Ant (Antenna) A

This SMA connector is attached internally to the mobile phone module. The supplied antenna should be connected to this connector. For best results it is advisable to place the 2 antennas as far apart as practical and in areas of good cell phone reception.

3. Line Out

This male XLR audio connector carries balanced line level (0dBu) analogue audio that the phone module is receiving.

Using the divert facility it is possible to route the incoming audio from the phone to either this output XLR or the handset interface. It is possible to adjust this analogue output level using the 'Output Levels' menu.

4. Line In

This female XLR audio connector carries balanced line level (0dBu) analogue audio to the input of the phone.

Using the divert facility it is possible to route the audio to the phone from either this input XLR or the handset interface.

5. Ant (Antenna) B

This SMA connector is attached internally to the mobile phone module. The supplied antenna should be connected to this connector. For best results it is advisable to place the 2 antennas as far apart as practical and in areas of good cell phone reception.

6. Dante® Ethernet Connector

If fitted this Neutrik Ethercon Ethernet connector provides 4 x bi-directional Dante®/ AES67 network audio circuits. The 4 circuits are split 2 for each phone module.

The audio output circuits to the network are in parallel with the rear panel Line out XLRs and the handset interfaces' earpiece.

The audio inputs to the phone from the network are mixed together with the Line in XLR input and the mouthpiece of the handset interface.

Please note the Dante Network interface board is an optional item and is only fitted if by Glensound if ordered at the same time as the GS-MPI005HD MKII. It is possible to order this interface and fit it retrospectively yourself at a later date.

7. Handset Interface

This connector allows a normal analogue telephone handset to be connected to the GS-MPI005HD MKII.

Once connected the handset can be used to answer calls (when an incoming call is received just pick up the handset to answer). If used like this then the phone call's audio will only be present on the handset and not the rear panel XLRs (or Dante Broadcast Interface).

To transfer audio between the handset and XLR/ network interface use the on-screen divert symbol.

8. DC Loops

This 9 pin female D connector provides 5 general purpose inputs/ outputs.

Using the GPIO menu on the touch screen each of the 5 circuits can be set to either an input or an output and their functionality can be assigned.

9. Mains

A standard IEC plug is fitted for powering the unit by a mains supply. The attached mains circuit MUST supply an earth.

An internal fuse is fitted to protect the unit and a filtered IEC plug is used.

The GS-MPI005HD MKII can operate on mains voltages between 100 – 240 VAC and when fitted with 2 x phone modules consumes 10 Watts.

MAKING A CALL

There are 3 ways of making a call, the most common ways are using the touchscreen or the optional telephone handset. The 3rd way is to use a GPI to dial a contact (see GPIO menu).

Using the Touchscreen

- 1) Press the 'Mobile' phone icon



- 2) Either select the keyboard to dial a number



- Or select a recent call

If you select a recent call then an option screen will appear to either call the number or add the number to the contact list. The default is 'CALL', then just click 'OK' to make the call.

- 3) Select the number you want to dial on the touchscreen keyboard



- 4) Then press the off hook/ dial icon

Using the Optional Handset Interface

- 1) Pick up the handset (The dialling keypad will appear on the touchscreen)
- 2) Enter the number to call on the handset
- 3) Wait for the call to initiate

ANSWERING A CALL

There are 3 ways of answering a incoming call, the most common ways are using the touchscreen or the optional telephone handset. The 3rd way is to use a GPI to answer the call (see GPIO menu).

Using the Touchscreen

An incoming call screen will appear when the GS-MPI005HD receives a call.

The caller's phone number will be displayed.

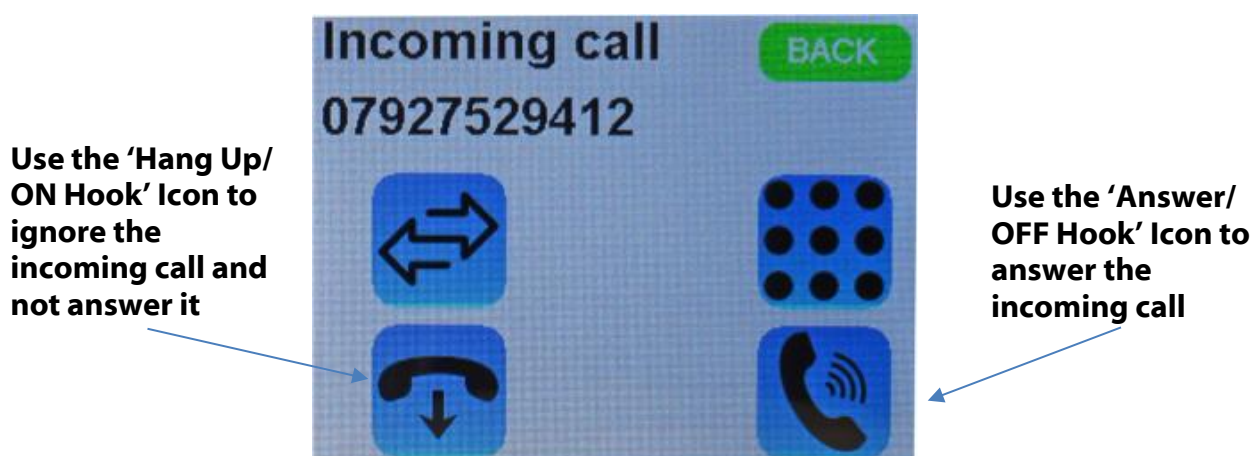

Using the Optional Handset Interface

Pick up the handset and take it off hook to answer the call.

DIVERTING/ TRANSFERRING A CALL BETWEEN THE HANDSET & XLRs

The audio to/ from the mobile phone only ever appears on either the optional handset interface or the rear panel XLRs (or the Dante® network audio equivalent of the above). It never appears on both circuits at the same time.

When you make or answer a call the audio will automatically appear on the circuit that you use. If you use the touchscreen to initiate the call then the call's audio will appear on the rear panel XLRs (called 'BROADCAST' in the transfer menu) and if you use the handset the call's audio will appear on that.

When a call is in progress the touchscreen will show the following screen

**Use the divert/
transfer icon to
display the
current setting**

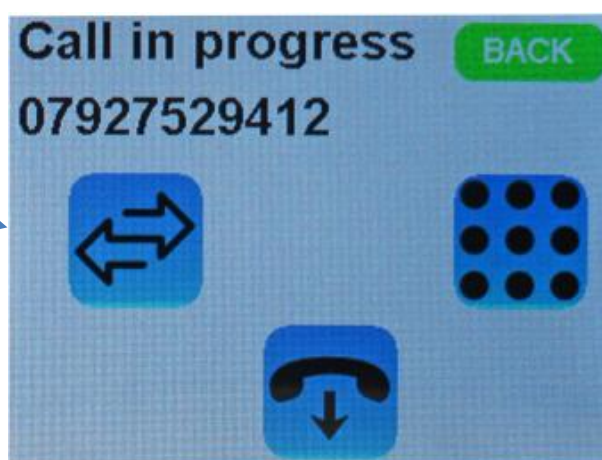

**If you've answered
the call on the
handset you'll see
this option.**

**Note:
As soon as you
press the 'Transfer
to broadcast' the
audio will route to/
from the XLRs/
Dante broadcast
circuit**

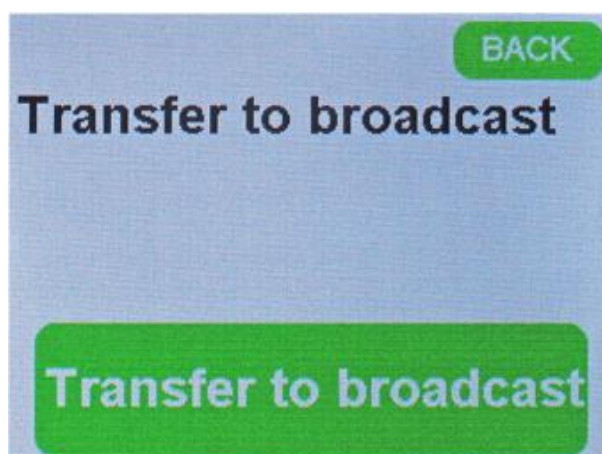

If you've answered the call on the touchscreen you'll see this option

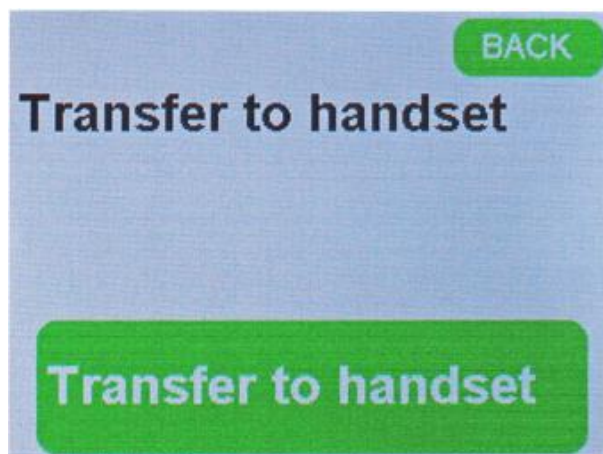

If the handset is currently on hook it will ring and the audio won't transfer until the handset has been answered.

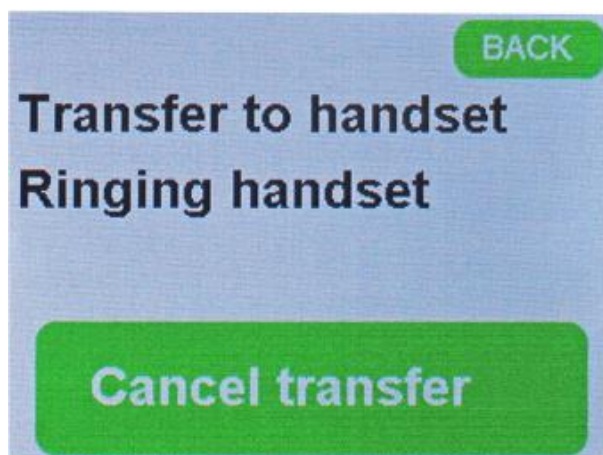

NOTE:

It is possible to set a GPI to divert/ transfer the call between the 2 circuits. Please see the GPIO section of this handbook for more details.

SENDING DTMF TO THE LINE

It is possible to send DTMF tones to the mobile phone circuit.

DTMF can be sent either from the touchscreen or from the optional telephone handset.

Using the Touchscreen

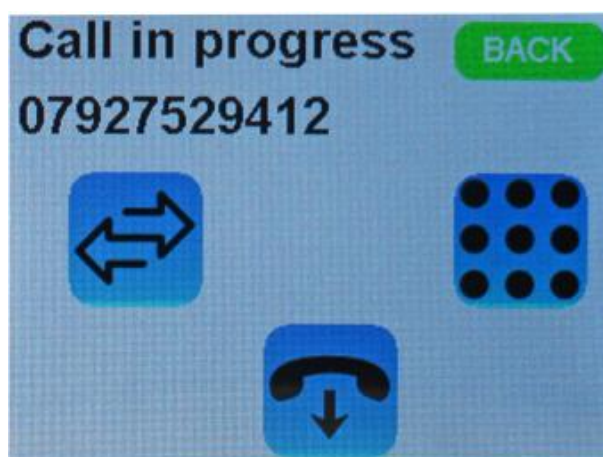

From the Call in progress screen select the keypad icon

The keypad will be then be displayed.
Pressing any number / * / # key will send the associated DTMF tone to the mobile phone circuit.

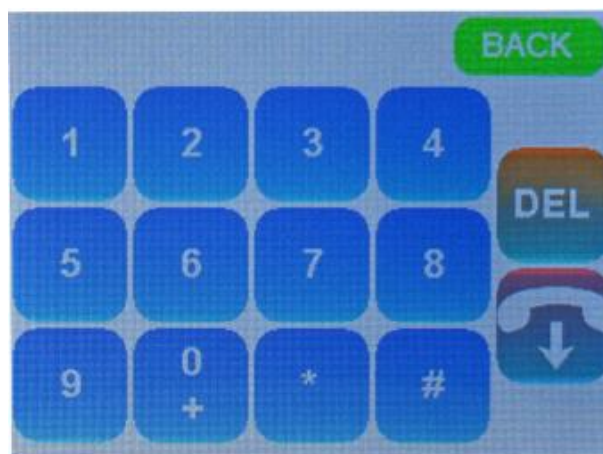

If you press the hangup icon while on the DTMF call you will end the call!

Using the Handset

Make sure that the call is currently transferred to the handset and then just use the handsets keypad to send the DTMF tones.

USING THE TOUCHSCREEN/ MENUS

The touchscreen is a resistive touch type. This means that it needs a slightly more firm push to operate than an average domestic mobile phone that uses a capacitive touchscreen.

Resistive touchscreens generally work well when operated by a stylus/ pen.

Home Screen

Name of Telecom Operator

Current Network Service

Indication of RF Signal Strength



Mobile Icon

The mobile icon provides access to making calls. When you press it a call history list first appears:



If the 'KBD' option is selected in the previous screen then the keyboard will appear:

Use the number keys to select the phone number you want to call and then press the red 'phone' icon to dial

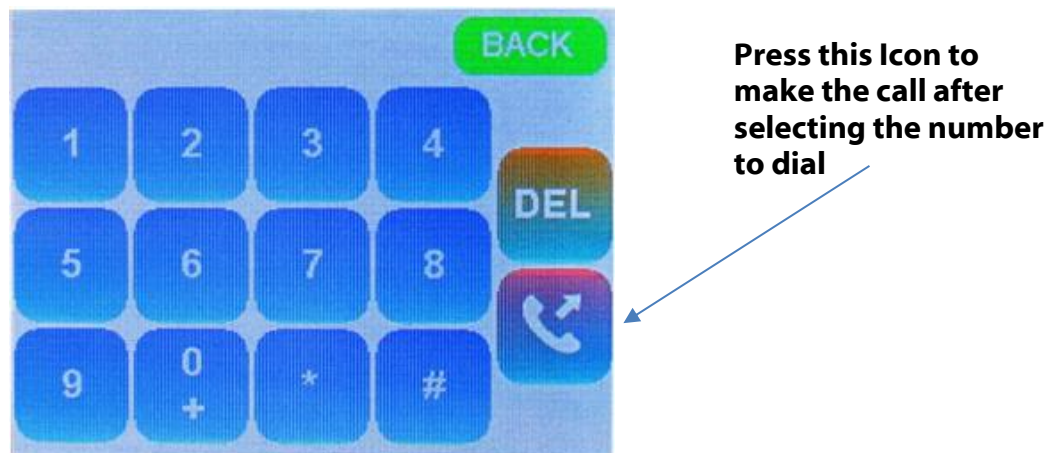

Contacts Icon

The contact icon provides access to a simple contact list and is ideal for storing regularly used numbers.

When entering the contact menu you will see a list of stored contacts, you can scroll up/ down through this list using the touchscreen.

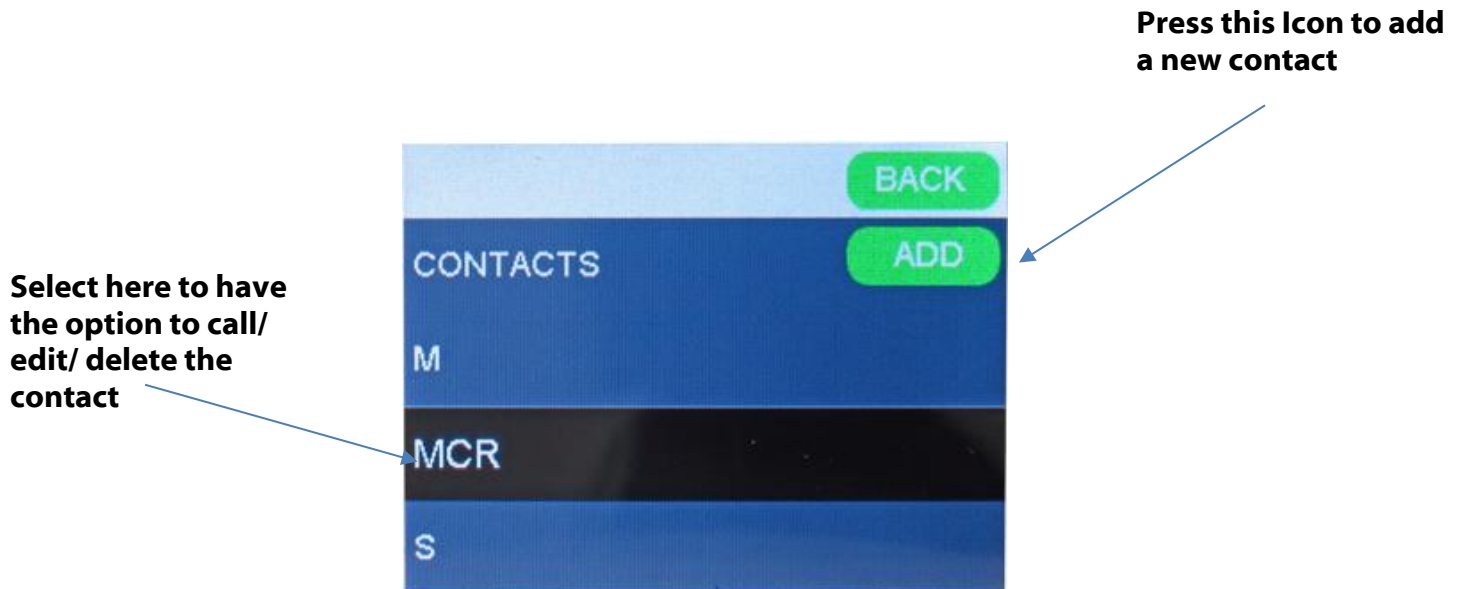

Adding a Contact

The adding a contact menu is often best operated using a stylus or firm object such as a pen (with the tip retracted).

The list of letters and numbers can be scrolled through (left / right) using the touchscreen.

When you first start adding a 'Name' or 'Tel' tap the name or tel box that you want to complete before starting to add the name or number.

Deletes the last added letter or number

Changes the letters between upper and lower case

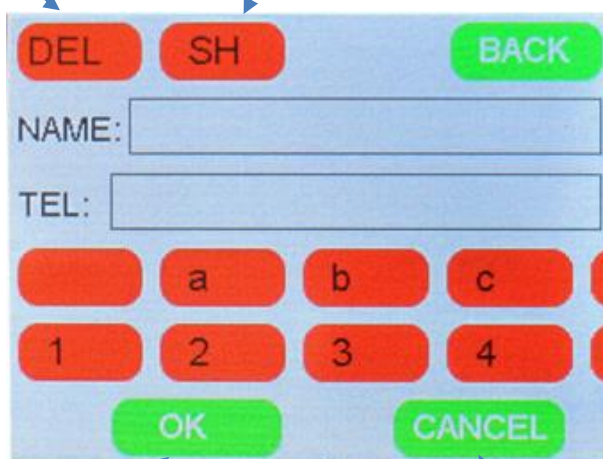

Saves the contact

Cancel without saving and return to home screen

The Settings Icon

Pressing the settings icon allows access to the settings menu.

You can scroll up/ down through the settings options, the available options are:

Network
Display
Sounds
Auto answer enable
Call transfers divert to Dante only NOT handset handset is disabled
MAC Address
About

**Select the setting
that you want to
make changes for**

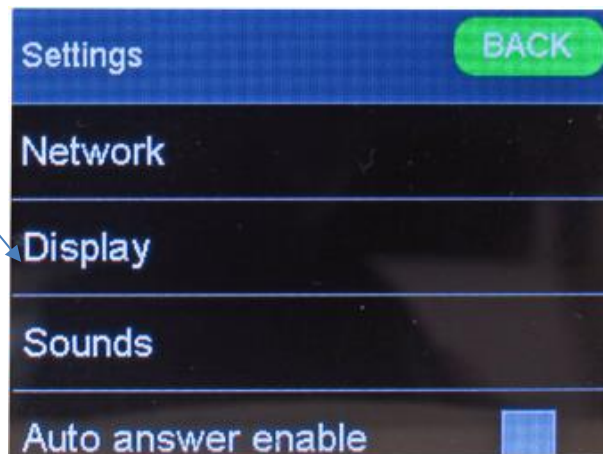

**Use the
touchscreen to
scroll up/ down
to see all the
options**



Network Settings Options

There are just 4 options in the network settings menu. The default option should always be 'Auto' whereby the phone will try to lock onto 4G and then only try to lock onto 3G or 2G if there is no 4G (or 3G) signals available.

If you select the 2G, 3G or 4G options then this forces the phone only to try to communicate on that type of network circuit.

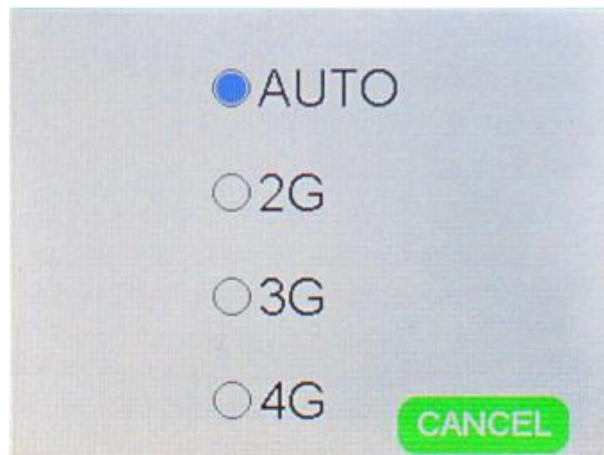

USEFUL TIP:

At large events/ gatherings there is often not enough cell phone circuits/ capacity available for the amount of people wishing to use them. As all modern smart phones are data hungry they invariably only ever try to work on 4G and 3G circuits and rarely try to use 2G if 3 & 4 are available.

Therefore to get a reliable telephone call in a congested area switch the GS-MPI005HD to work on 2G only.

Obviously this only works if you're in an area where 2G is available and have a sim card that supports 2G.

Remember to switch it back to auto at the end of the event ready for your next broadcast.

Display Settings

Just two options are available when in the display settings menu.

When adjusting the Brightness of the display a fader appears on the screen. This fader can be operated either by using the touchscreen or by using the 'Control Shaft Encoder'

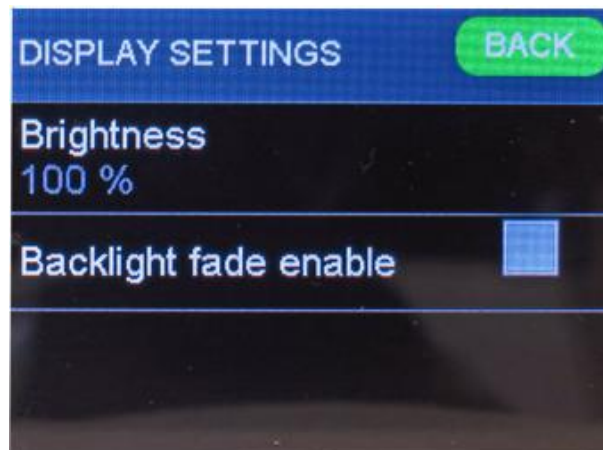

When 'ticked' the Backlight fade enable automatically slowly dims the backlight to reduce the GS-MPI005HD's screen presence in a studio when it is not in use.

As soon as the display is touched, the Control Shaft Encoder used or an incoming call is detected the display returns to its pre-set brightness level, before gently fading again.

Sound Settings

The Sound Settings menu provides access to the incoming call sounder volume and options to enable the sounder and the external telephone handset ringer.

Internally fitted to the PCB each phone module has a sounder. This sounder can be used to indicate an incoming call.

When adjusting the Sounder Volume a fader appears on the screen. This fader can be operated either by using the touchscreen or by using the 'Control Shaft Encoder'

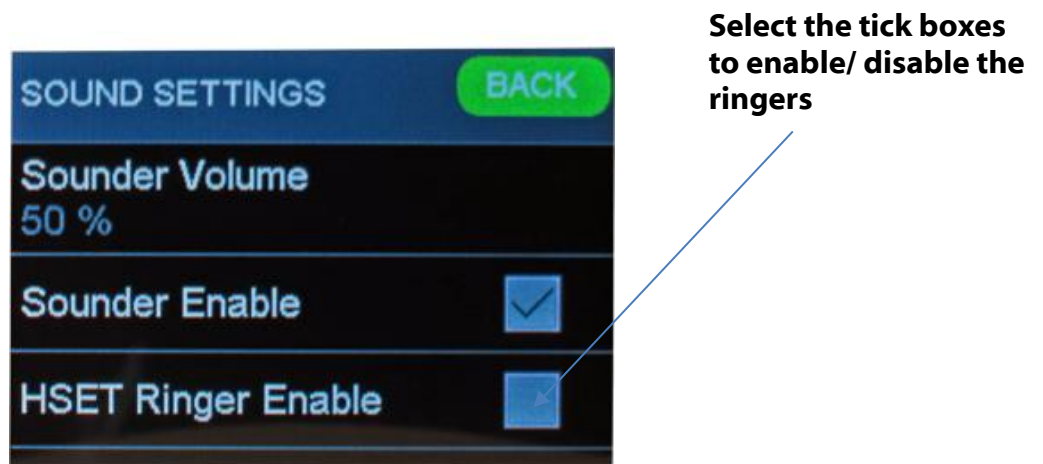

NOTE:

In the GPIO menu there is a 'Mute Ringers' option for muting both the sounder and handset ringer via an external trigger.

Auto answer enable

The tick box for the auto answer enable option in the settings menu is designed to be simple and easy to use.

If the tick box is 'ticked' then the GS-MPI005HD will answer an incoming call automatically and if it is not ticked then you must manually answer the call.

Call transfers divert to Dante only NOT handset

The tick box for this option disables the handset.

If the tickbox is checked then the handset cannot be used for making / receiving calls.

The reason for this option is to allow the 'handset' circuit of the Dante to always work even if the actual handset is on hook.

MAC Address

The MAC Address is programmed at the factory and once set cannot be changed.

To see the MAC address that is assigned to the phone module then just click on the MAC address label.

This MAC address relates to the phones Ethernet port, each phone module fitted have their own Ethernet port and MAC address.

This MAC address does not apply to the Dante® network interface Ethernet port. The MAC address of this can be found using Dante Controller and looking in the Status tab.

About

The About settings page provides useful information.

FW stands for Firmware and is the software version currently installed

This is the mobile phones unique IMEI number

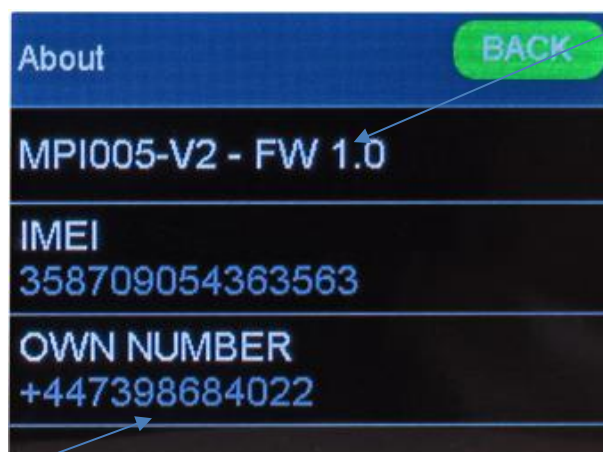

If a SIM card is installed this is its telephone number

Output Levels

The output levels menu allows you to alter the audio levels being sent to various circuits within the unit.

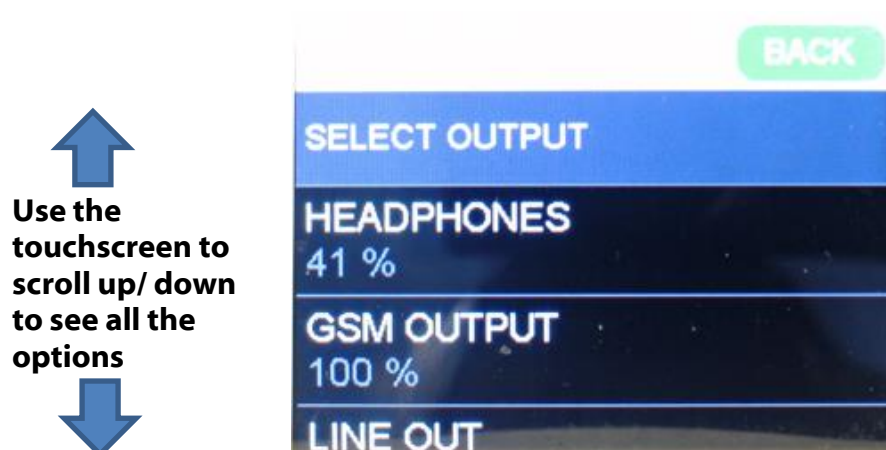

Options and brief descriptions are below:

HEADPHONES

This is the headphone volume setting, although the headphone volume can be altered from this menu it can also be altered at any time by adjusting Control Shaft Encoder

OUTPUT TO GSM

This is the 'output' level of the internal electronics being sent to the input of the mobile phone module. So some people may consider it an input level!
If this is set to 100% and you've got outgoing distortion on the mobile phone circuit then it can be turned down to reduce the incoming level from the analogue line in and the Dante® network input.

LINE OUTPUT

This is the level being sent to the analogue line output XLR

OUTPUT TO HANDSET

This is the level being sent to the optional telephone handset

OUTPUT TO DANTE GSM

This is the output level being sent to the Dante® network interface from the mobile phone. This is the equivalent output of the analogue line level output on the rear of the unit.

The mobile phone output can be transferred between this output and the Dante From Handset output and will only exist on one circuit at a time.

OUTPUT TO DANTE HANDSET

This is the output level being sent to the Dante® network interface from the mobile phone. This is the equivalent output of the audio being sent to the telephone handset.

The mobile phone output can be transferred between this output and the Dante From GSM output and will only exist on one circuit at a time.

GPIO Menu

This menu provides access to the GPIO (General Purpose Input and Output) circuits. There are 5 GPIO circuits which are provided on the rear panel D connector and each of the circuits can be set as an input or an output (for connection information see the wiring section at the end of the manual).

You can scroll up/ down between the 5 GPIO circuits.

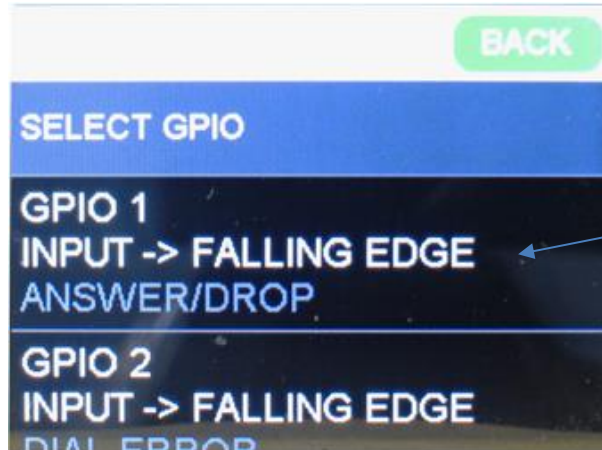
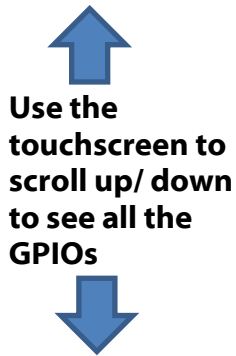

Scroll to the GPIO that you want to set and click it

Select enable to turn on or disable to turn off

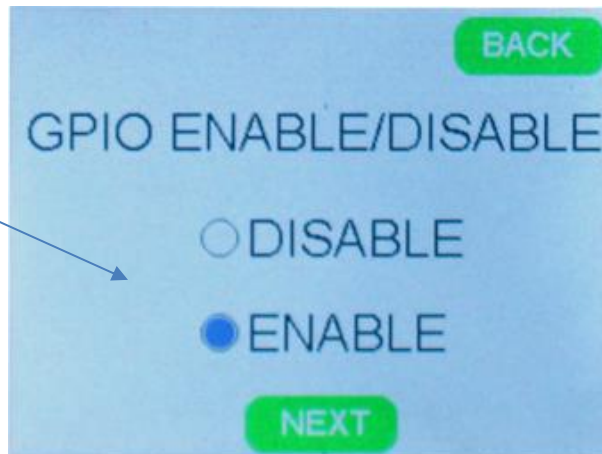

Select if you want this GPIO to be an input or an output

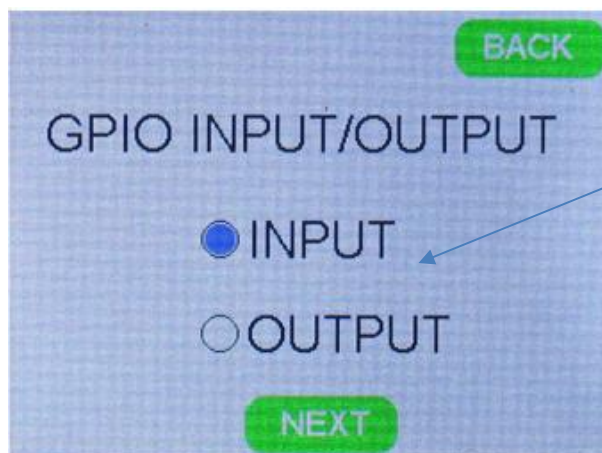

Choose the event to be associated with the selected GPIO

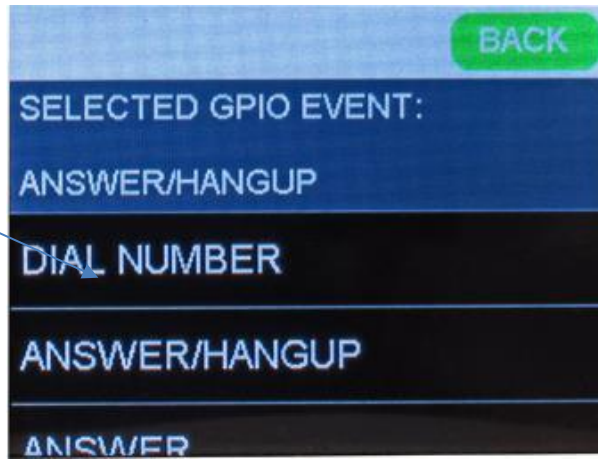

The Input Options are:

- DIAL NUMBER
- ANSWER/ HANGUP
- ANSWER
- HANGUP
- MUTE RINGERS

INPUT EVENTS (GPI)	GPI TYPE
DIAL NUMBER <i>If you select this then the contacts list will open to select who to call</i>	Momentary
ANSWER/HANGUP <i>Triggering this will answer an incoming call or end one that is in process</i>	Momentary
ANSWER	Momentary
HANGUP	Momentary
MUTE RINGERS	Latching
TRANSFER <i>Transfers the current call between the XLR/ Handset</i>	Momentary

The Output Options are:

- DIAL NUMBER
- ANSWER/ HANGUP

OUTPUT EVENTS (GPO)	GPO TYPE
INCOMING CALL	Latching
CALL IN PROGRESS	Latching

RISING EDGE/ FALLING EDGE GPI

When setting a GPI an options screen asks if the input trigger should be a 'RISING EDGE' or a 'FALLING EDGE'

RISING EDGE: Use this option if you want to trigger the GPI event when you disconnect the GPI's input from ground.

FALLING EDGE: Use this option if you want to trigger the GPI event when you join the GPI's input to ground.

HIGH LEVEL/ LOW LEVEL MUTE RINGERS GPI

The mute ringers GPI is a latching circuit i.e. its input needs to be held high (or low) for the whole time that you want the ringers to be muted.

When setting the mute ringers GPI an option screen asks you if the input trigger should be 'HIGH LEVEL' or 'LOW LEVEL'

HIGH LEVEL: Use this option if you want the mute ringers event to be triggered by the GPI's input not being connected to ground.

LOW LEVEL: Use this option if you want the mute ringers event to be triggered while the GPI's input is joined to ground.

LOW LEVEL/ HIGH LEVEL GPO

When setting a GPO an options screen asks if the output should be 'LOW LEVEL' or 'HIGH LEVEL'.

LOW LEVEL: If this option is selected then when the GPO event is active the output will go low (i.e. there will be no output volts)

HIGH LEVEL: If this option is selected then when the GPO event is active the output will be high (i.e. there will be 3.3 Volts on the output)

Headphone Menu

The headphone mixer menu allows you to select which source(s) and at what level it/they are sent to the front panel headphone output.

To enable a source to be routed to the headphones then first the tick box next to that source must be made. Then the level of that source must be set by tapping the source to bring up the source's fader. The fader level can be adjusted either using the touchscreen or by adjusting the Control Shaft Encoder

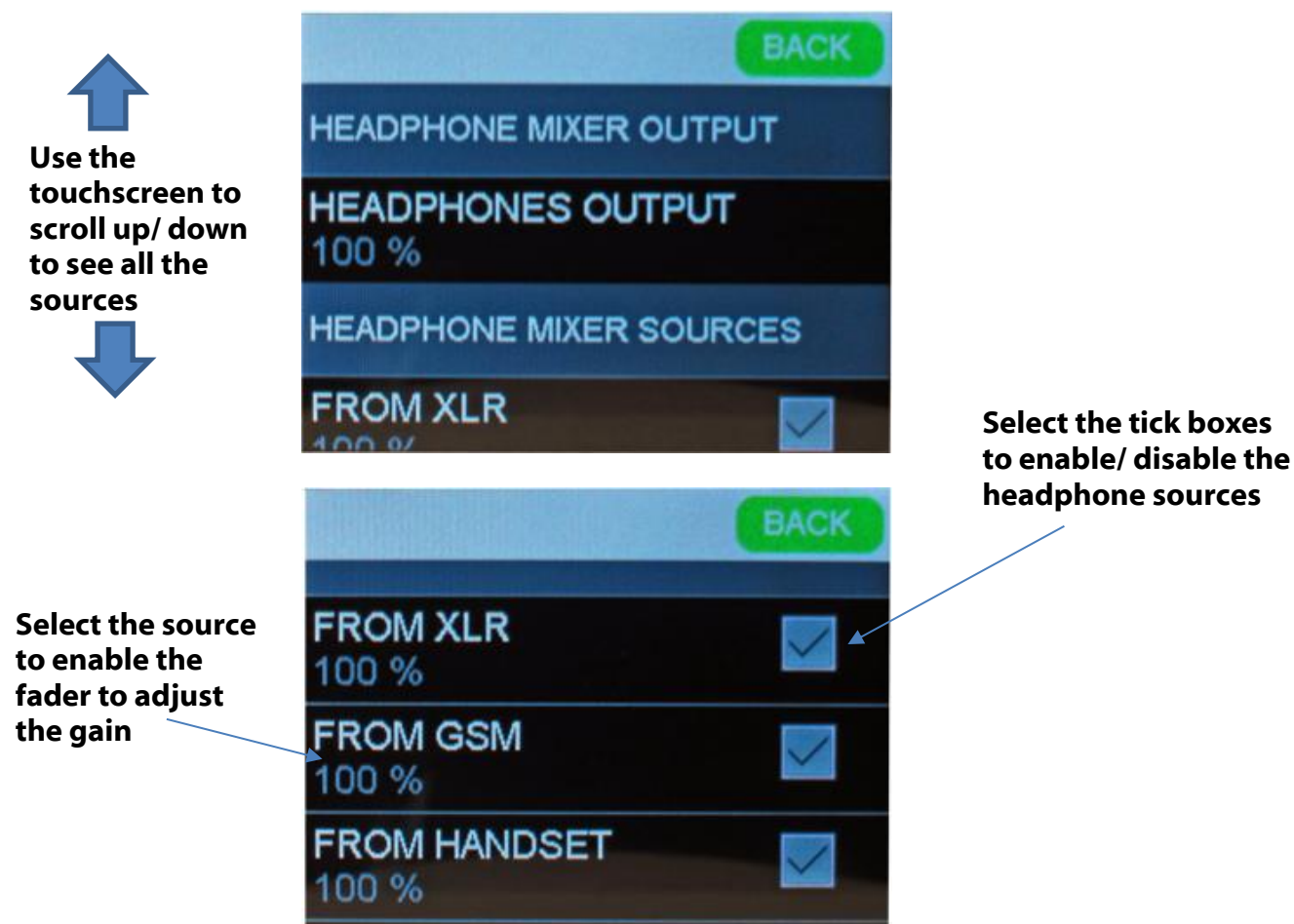

The headphone menu consists of the following items:

HEADPHONE MIXER OUTPUT

HEADPHONES OUTPUT....This is the overall headphone volume level

HEADPHONE MIXER SOURCES

From XLR

From GSM

From Handset

From Dante GSM

From Dante Handset

The below headphone sources are outputs from the GS-MPI005HD that can be monitored in the headphones if required:

TO XLR

TO GSM

TO HANDSET

TO DANTE GSM

TO DANTE HANDSET

WEB CONTROL INTERFACE

The MPI005HD MKII has a web interface that allows remote control of the unit from a web browser on a computer that it connected to the same local network as the device.

Make sure the MPI005HD MKII is connected to the network via the 'Ethernet' port of the corresponding phone unit if you want to access the web server.

Note: The device must be on firmware **version 1.5** to use the web server. See the version of firmware you have by navigating to 'Settings' – 'About' on the touch screen.

To grab the latest version from GlenSound, go to <https://www.glenSound.co.uk/product-details/gS-mpi005hd-mkii/> and select the 'Firmware Latest Version' tab for the device firmware.

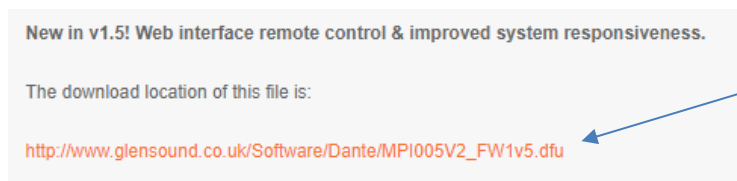

Click the link to download the .DFU file

See [page 43](#) for instructions on how to update the device firmware.

Configuring the device for web access

Press to access web server configuration

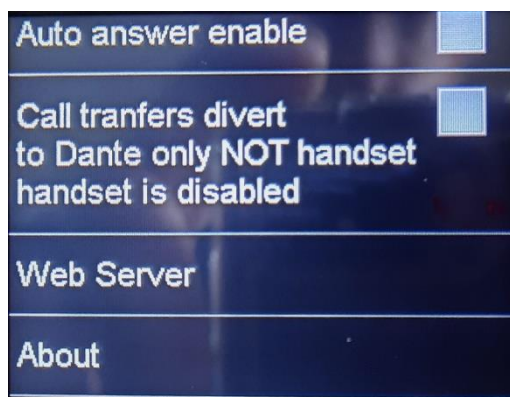

Settings page

Shows device's MAC address

Allows network router to assign devices IP address

Allows setting a static IP address

Allows setting of subnet mask

Allows setting of network gateway IP address

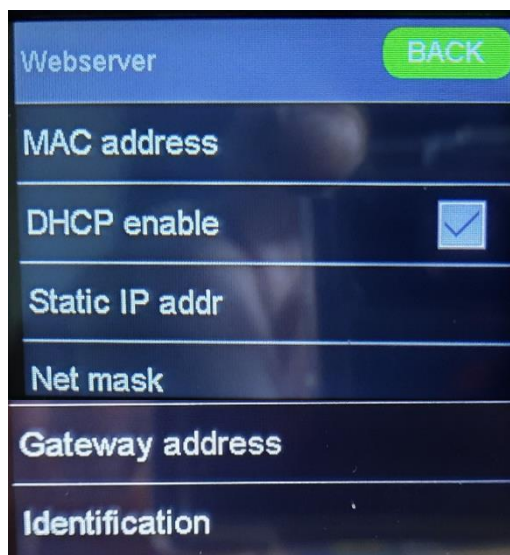

Web Server configuration page

Allows setting of a device specific unique name

Set local static IP address



Set device identifier ID



Set a device name to use for connecting to the web interface

Connecting to the device

1. Open a web browser on a computer connected to the same network as the device via it's 'Ethernet' RJ45 connector.
2. Enter the device's identifier ID in the address bar of your browser.

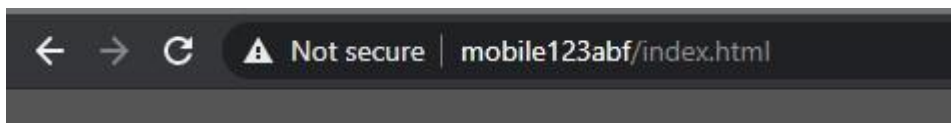

3. The web page will load and take you to the home screen.

Using the web interface

Connected Mobile SIM network

Mobile network strength



Home screen

Side menu - click 'Menu' to open

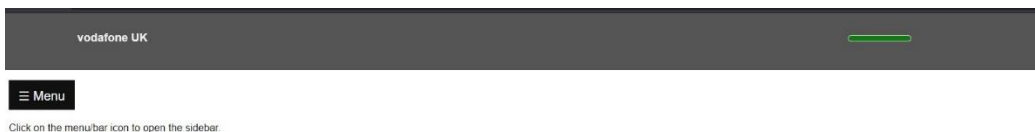

Phone screen

Dial pad



Press Dial to make call

OPTIONAL DANTE®/ AES67 NETWORK INTERFACE

The optional Dante®/ AES67 network interface can be factory fitted or retro fitted at a later stage if required.

The interface uses Audinate's ultimo chipset which provides 4 bi-directional network audio channels at 48kHz. The ultimo chipset is also AES67 compliant.

The 4 network audio channels are split 2 for each phone module. The 2 bi-directional channels for each phone are set such that 1 audio pair are in parallel with the rear panel analogue audio XLRs and the other pair are in parallel with the audio being sent/ received from the handset.

The information below is only meant as a very basic guide. Full details of the power of Dante network audio and instructions for using it can be found at www.audinate.com

Dante Circuit Names

4 network audio circuits will always be present even if you have just 1 mobile phone fitted.

The default circuit names are GSM A, Handset A and GSM B, Handset B. whereby the GSM circuits are in parallel with the rear panel XLRs (the XLR input and the network input are mixed together) and the Handset circuits are in parallel with the handset interface (the microphone input from the handset is mixed with the network input).

A and B define which physical phone module the circuits relate to:



Getting Dante Controller

If you are connecting the GS-MPI005HD MKII to a new Dante network the first thing you will need to do is to get the free Dante controller software from Audinate. This can be downloaded by visiting Audinate's web site at www.audinate.com

Connecting GS-MPI005HD MKII To the Network

The mobile phone rack can be connected to the network that you are going to use for your audio distribution simply by plugging in to the RJ45 network connection on the rear. Once connected to the network it will be possible to see the GS-MPI005HD MKII from within the Dante controller and route its' audio circuits.

Audio Over IP Network

We strongly recommend that you consider your network topology carefully and would not recommend sharing broadcast audio and general data on the same network.

For more details of audio over IP network structure please visit www.audinate.com

Running Dante Controller

At the time of writing this manual the Dante Controller looks as per the screenshot below:

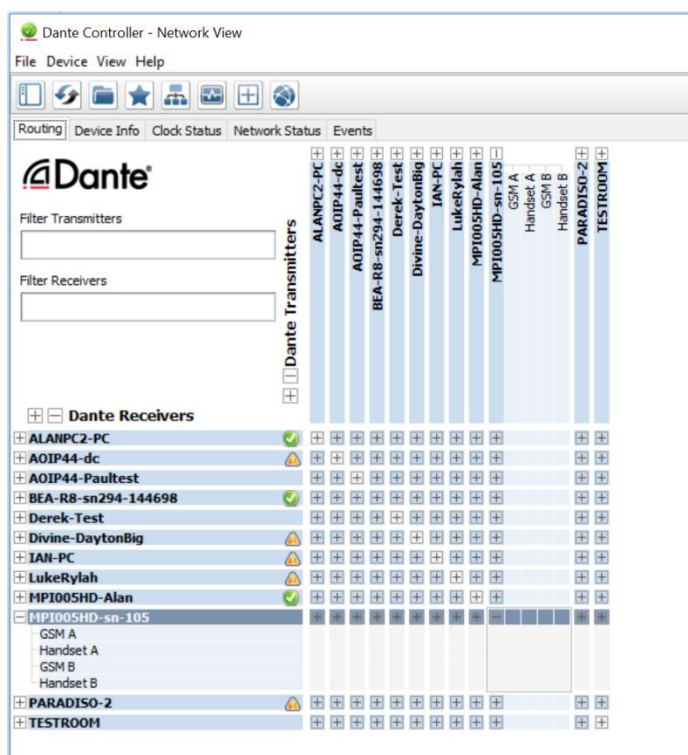

The GS-MPI005HD MKII will have been named at the factory during test to allow them to be identified by the Dante controller.

The format used for the factory name is:

'MPI005HD-sn-XXX'

Where 'MPI005HD' refers to the Glensound product i.e. GS-MPI005HD MKII.

The '-snXXX' refers to the serial number of the unit which can be found printed on the rear or side of the unit.

The unit may be renamed in Dante controller by opening the 'Device view' window and selecting MPI005HD in the drop-down menu. Go to the 'Device Config' tab and change the name with the Rename Device box.

Note if you upload a new DNT file or clear the devices config then the name will change to MPI005HD-xxXxXx whereby the 'X's refer to the devices MAC address.

Dante Controller TIP

If you have never run Dante controller before then make sure that on the bottom left of the Dante controllers' screen 'P' or 'S' is next to a green square as this indicates that it is connected to a network. By clicking 'P' or 'S' a pop up box opens to allow you to set what network interface the controller is using.

Device Not Showing Up In Dante Controller

If your Dante™ device does not show up in Dante™ Controller then the most likely issue is that the device's IP Address is not appropriate for your network.

- A) It maybe that the device is set to obtain an IP address automatically using DHCP (this is the default configuration) and your network is setup for fixed IP addresses only and does not have a DHCP server.
- B) It maybe that the device has had a fixed IP address assigned but that this address is not suitable for your network.

The solution to both scenarios is basically the same.

- 1) You must connect your Dante™ device directly to the Ethernet port of your computer using an Ethernet cable.
- 2) Make sure that your computer is set to 'Obtain an IP address automatically'
- 3) After a few minutes the Dante™ device should now appear in Dante™ Controller.
- 4) Double click the device name to open up device view.
- 5) Open up the 'Network Config' tab
- 6) Either turn on 'Obtain an IP Address Automatically' or correctly configure the 'Manually configure an IP Address' options for your network.
- 7) Click on 'Apply' to confirm the new settings, then disconnect the computer and reconnect the Dante™ device to your network.

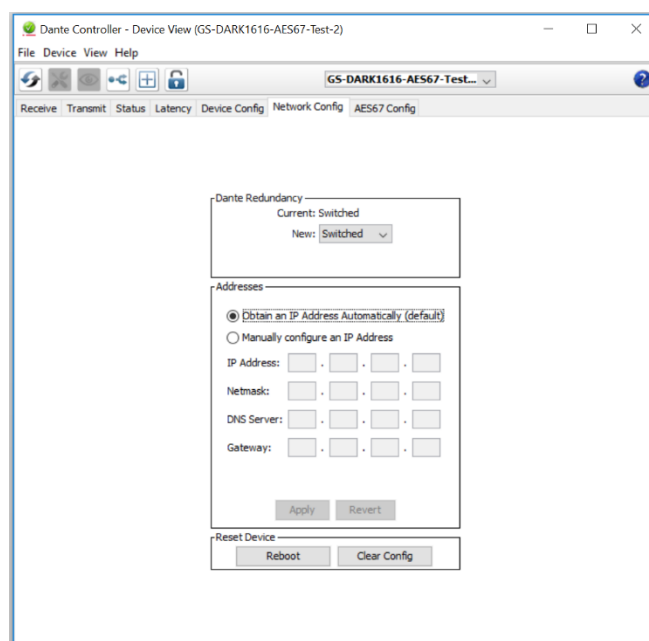

AES67 MODE

The GS-MPI005HD MKII uses a chipset from Audinate called the Ultimo for its network audio interface. Audinate are the company behind Dante® and as such the primary network audio protocol is Dante®, however Audinate have enabled their chip to comply with AES67 and therefore the GS-MPI005HD MKII can be set to AES67 mode for interaction with other AES67 devices.

Please note however that Glensound are relying on Audinate's AES67 interface and are unfortunately not able to provide full AES67 support for the unit. AES67 support should be sought directly from Audinate.

Turning On AES67 Mode

If you want to use your GS-MPI005HD MKII on an AES67 network and it has not been set to AES67 mode then this can be set in Dante controller by double clicking the MPI005HD to open the Device View window where you will find an AES67 tab to enable AES67 support.

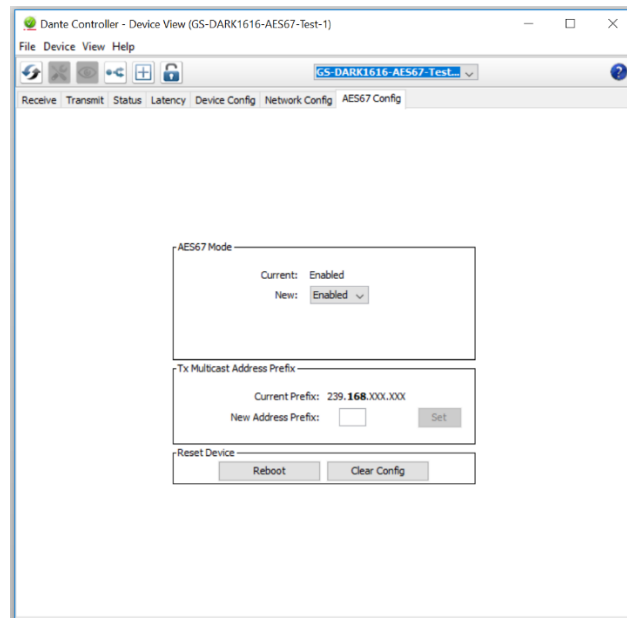

Once the AES67 drop down box has been enabled you'll have to reboot the MPI005HD MKII for the change to take effect. After the reboot go back to the AES67 tab and set the multicast prefix address to one that is suitable for your network.

Sending AES67 Audio

To transmit AES67 audio to the network a multicast flow must first be setup.

This is done by selecting the 'Create New Multicast Flow' Icon  in the Device View.

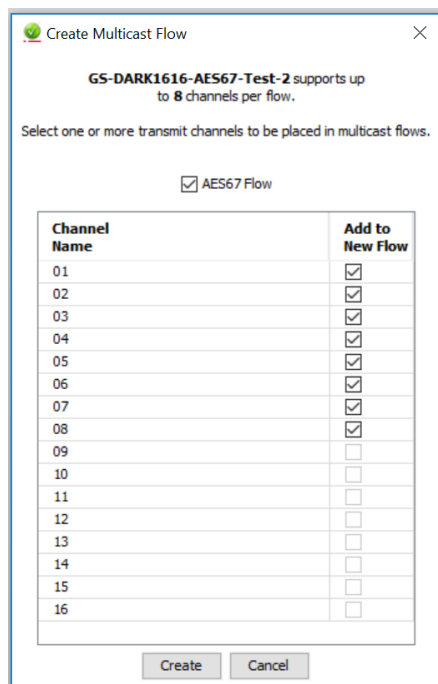

Tick the AES67 Flow check box, then select up to 8 channels to be included in the flow then click 'Create'

Once set the flows can be seen in the transmit tab of the device view.

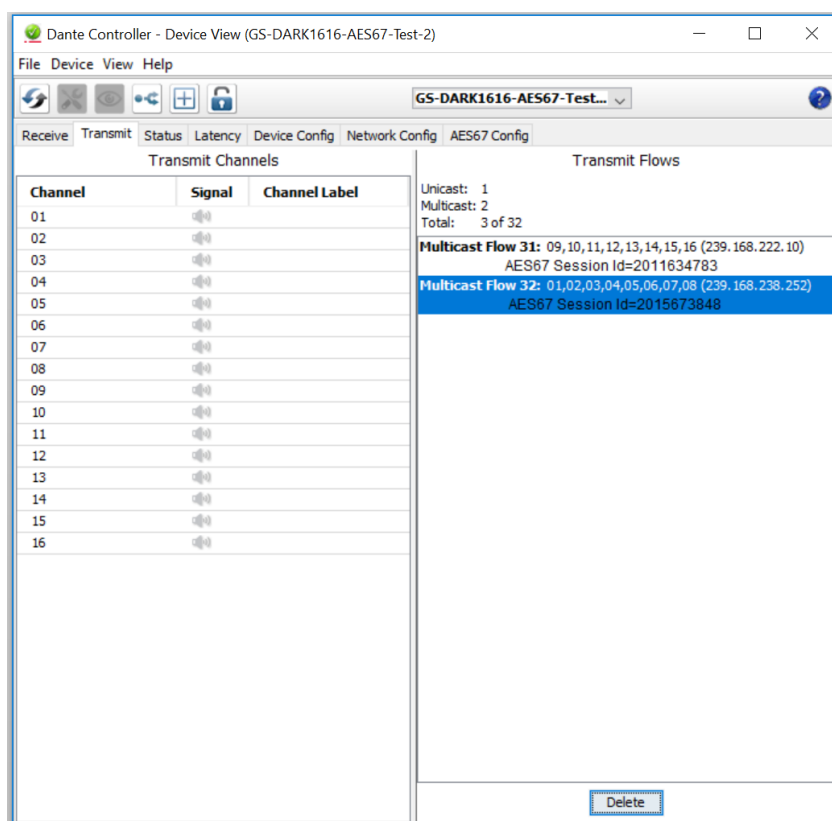

Receiving AES67 Audio

Once a compatible AES67 stream is detected on the network by Dante Controller the AES67 flows will appear in the Dante Transmitters section in the Routing tab.

AES67 Restrictions

AES67 flows can only be generated with the following constraints:

- Multicast Only
- Non-redundant
- Destination address in range 239.nnn.0.0 to 239.nnn.255.255 (239.nnn/16), port 5004
- 48kHz sampling rate
- 24 bit linear (L24) encoding
- 1 msec packet time
- Up to 8 channels per stream

Received AES67 flows have the following constraints:

- Multicast Only
- Non-redundant
- Destination address in range 239.nnn.0.0 to 239.nnn.255.255 (239.nnn/16), port 5004. Must match destination address range.
- 48kHz sampling rate
- L16 or L24 encoding
- 125usec, 250usec, 333usec, 1 msec packet time
- Up to 8 channels per stream

UPDATING FIRMWARE

Equipment needed

- A windows based PC
- USB Type A to Micro B cable
- A copy of 'DfuSe Demo' software
- The latest firmware from Glensound
- Mains power

Instructions

1. Download and install DfuSE Demo

'DfuSE Demo' is a firmware updating tool that is required for loading new firmware on to the GS-MPI005HD MKII.

It can be downloaded from the STMicroelectronics website found here: <https://goo.gl/AbzhsA>. It is the file named "STSW-STM32080".

Once you have downloaded this file you will need to extract the .exe "DfuSe_Demo_V3.0.5_Setup.exe", then run and install it.

2. Download firmware

The latest firmware for the GS-MPI005HD MKII can be found on the Glensound website, on the product page. Once you have downloaded the file, place it in a folder or location of your choice.

Name	Date	Type	Size
 Dark1616S1.1.1.dfu	21/03/2018 11:18	DFU File	47 KB

Figure 1 Example filename

3. Connect To A PC

Connect the GS-MPI005HD MKII to the PC via the USB cable. The micro USB connector is located on the front panel of the GS-MPI005HD MKII under the SIM card slot.



Figure 2 USB connector

4. Firmware update preparation

To prepare the GS-MPI005HD MKII for a firmware update;

1. Make sure the device is connected with USB
2. Press and hold down the CONTROL Shaft Encoder
3. Power on the unit
4. Release the CONTROL Shaft Encoder after a few seconds

Your PC should make an audible sound when this process is successful as windows is detecting a new USB device.

5. Loading the firmware

Now open DfuSe Demo.

If the GS-MPI005HD MKII successfully entered DFU mode then it will appear as 'STM Device in DFU Mode' under the 'Available DFU Devices tab'.

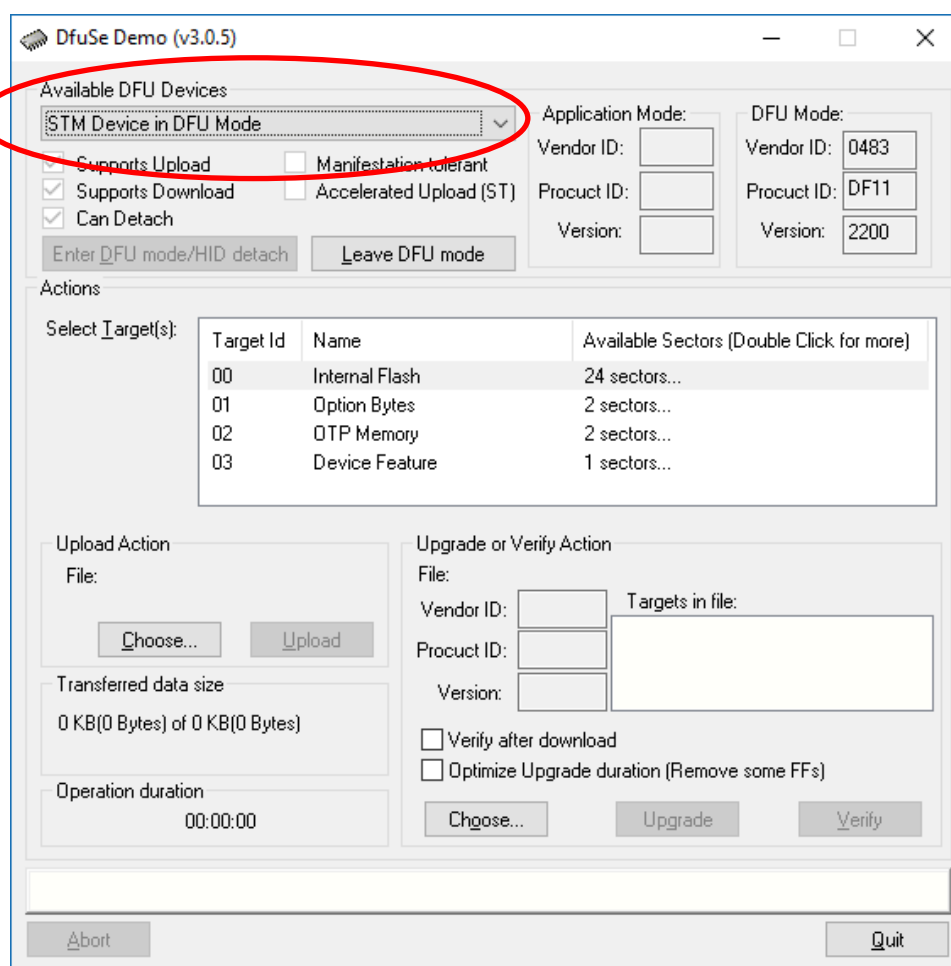

Figure 3 Device successfully recognised

Now the .dfu file needs to be selected so that DfuSe Demo knows the correct firmware to put on to the STM32 Device.

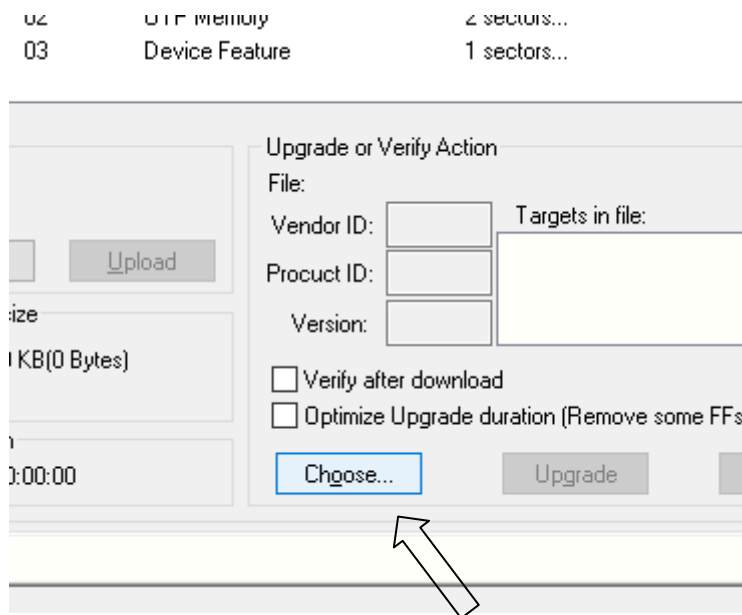

Figure 4 Choose .dfu file

Click choose and then select the .dfu file that you downloaded from the GlenSound website. This will be located in your downloads folder by default.

If the file loads successfully then it will read along the bottom 'File correctly loaded'.

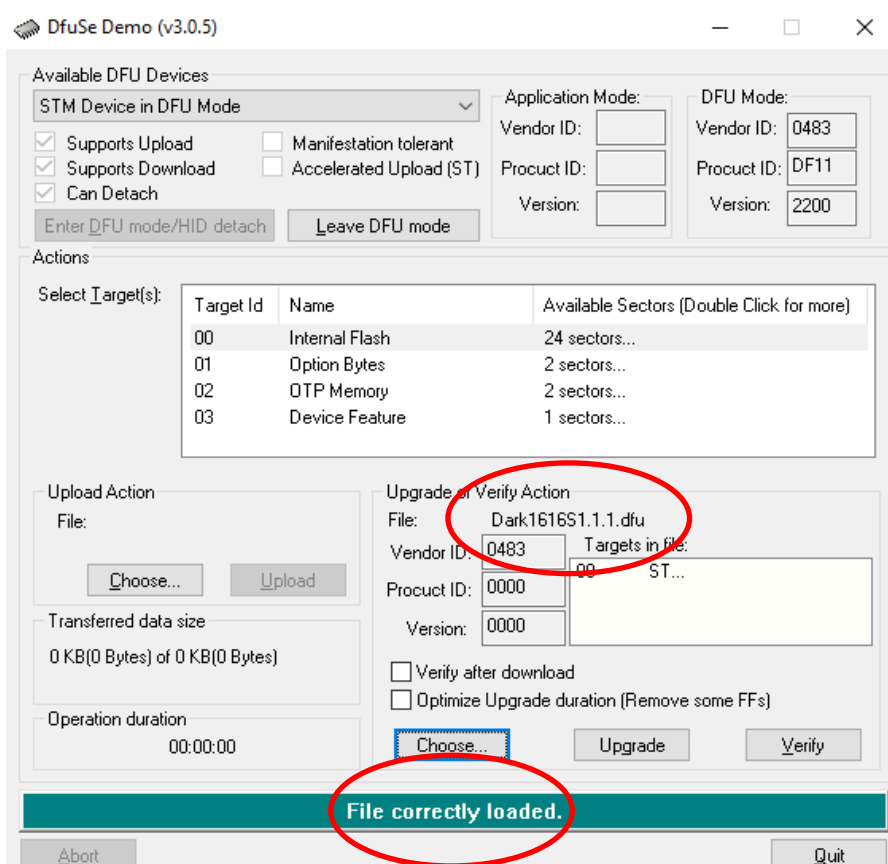

Figure 5 .dfu successfully loaded

6. Upgrading the GS-MPI005HD MKII firmware

The firmware is now ready to be put on to the STM32 Device. Tick the 'Verify after download' box first and then click 'Upgrade'.

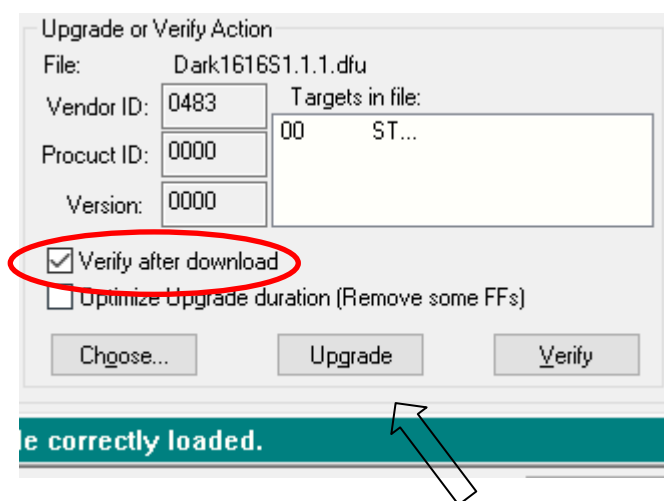

Figure 6 Upgrade

Click yes to proceed.

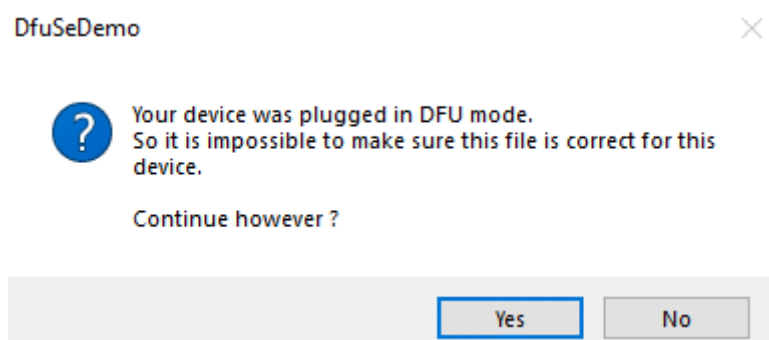

Figure 7 Start upgrade

The progress bar along the bottom will show the status of the operation.

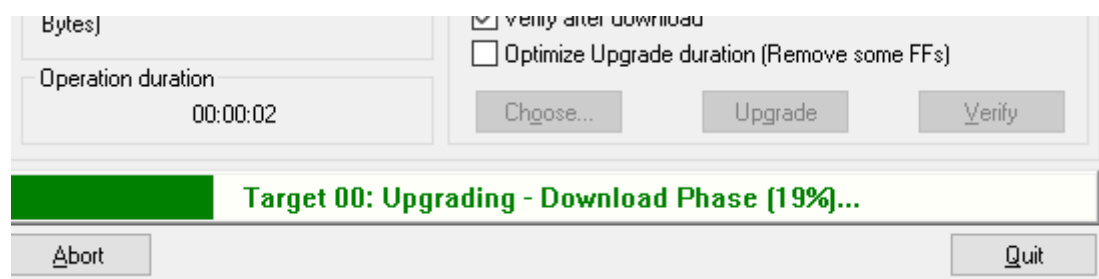

Figure 8 Upgrade status

If the operation was successful, DfuSe Demo will report that “Target 00: Verify Successful!”.

You may also see that it will report how much data was successfully transferred.

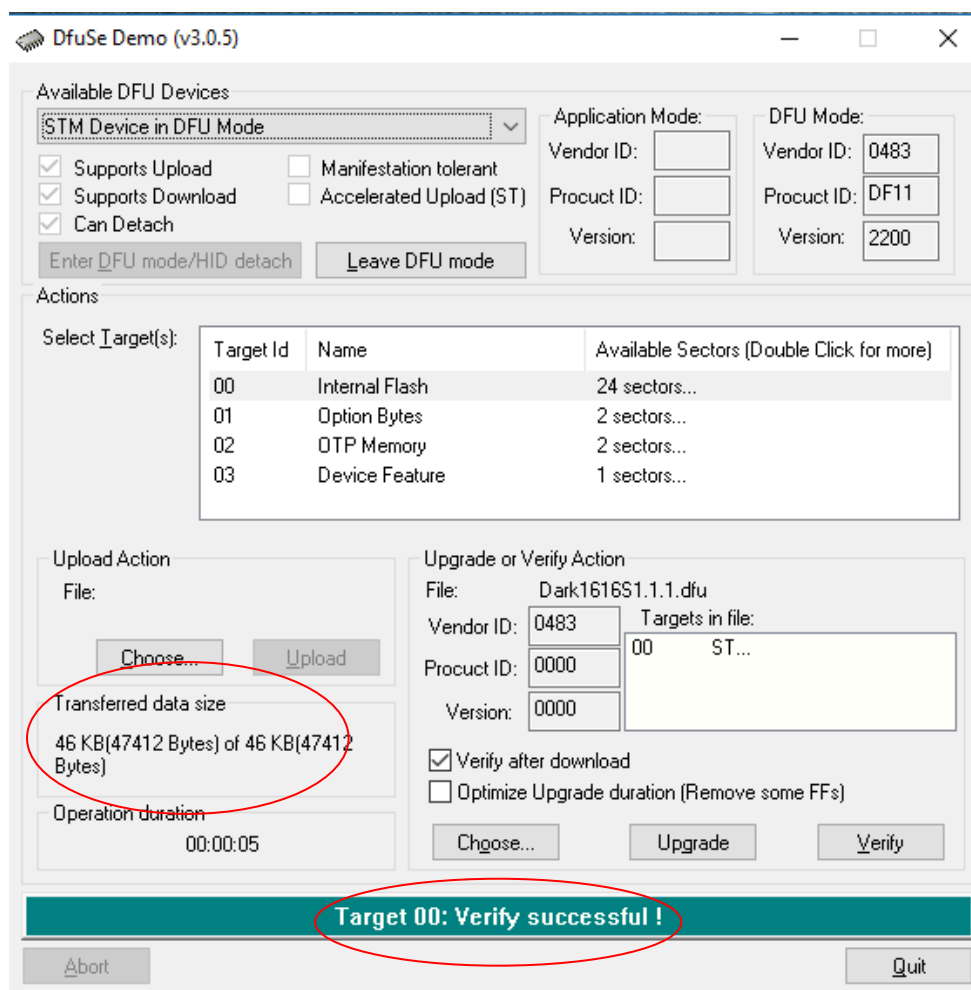

Figure 9 Successful upgrade!

7. Final steps

Now click “Leave DFU mode” to finish the procedure.

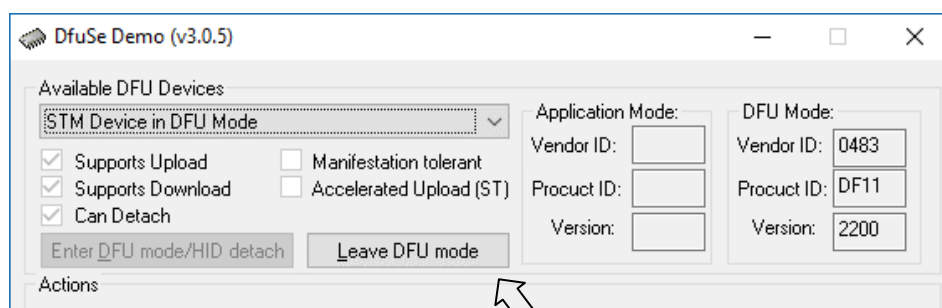

Figure 10 Final step

You may now disconnect the USB cable and continue to use the GS-MPI005HD MKII with the freshly updated firmware!

UPDATING THE ULTIMO CHIPSET

The Ultimo Chipset is a device supplied by Audinate that does most of the processing for the actual Dante/ AES67 network audio streams. There is one Ultimo Chipset in each GS-MPI005HD MKII. We supply special code (a .dnt file) that sets up/ initiates the Ultimo Chipset and makes it work in particular way that is compatible to the GS-MPI005HD MKII.

Finding Out Current Installed Version

Using Dante® controller double click on the GS-MPI005HD MKII device name in the routing tab to open the Device View box.
In the Device View box open the Status Tab.

The 'Product Version:' shows the currently installed version of Ultimo Chipset dnt code.

Finding Out What The Latest Available Version Is

Go the GS-MPI005HD MKII's web page at Glensound.com and open the 'Firmware Latest Version' Tab.

This will give both the latest version numbers/ file names and also the location to download the file from.

Updating the device

The firmware that runs in the Ultimo Chipset is updated using Audinate's Firmware updating tool. The updating tool and a user guide can be downloaded from Audinate's website:

<https://www.audinate.com/products/firmware-update-manager>

NOTE:

Please note we strongly advise that when you do the update that only your PC and the Dante device that you want to update are on the network to save accidentally updating the wrong Dante device.

WIRING INFORMATION

XLR & JACK Wiring

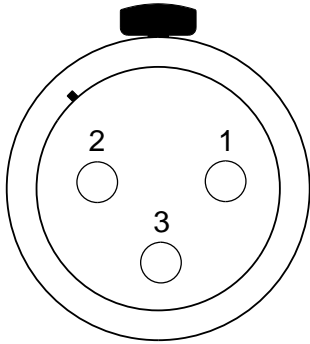

XLR SOCKET (FEMALE)

STANDARD XLR AUDIO PINOUTS:

1: Ground/ Earth

2: INPHASE/ POSITIVE/ MIC +

3: MATE/ NEGATIVE/ MIC -

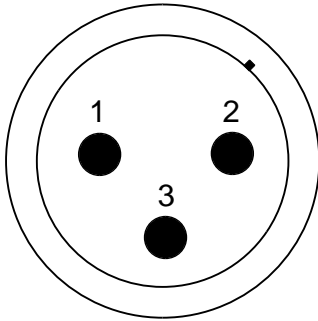

XLR PLUG (MALE)

STANDARD HEADPHONE WIRING:

TIP: A/ LEFT Ear

RING: B/ RIGHT Ear

SLEEVE: Common/ Earth

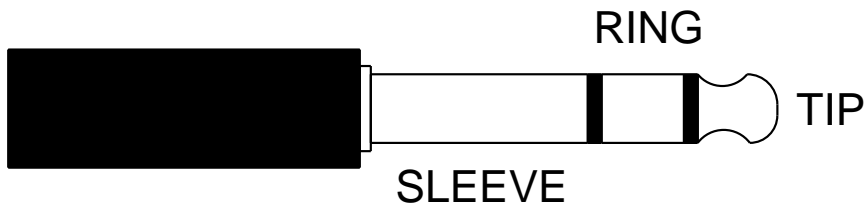

D9 Wiring & Loop Interconnecting To External Equipment

9 Pin D Socket Fitted to Device

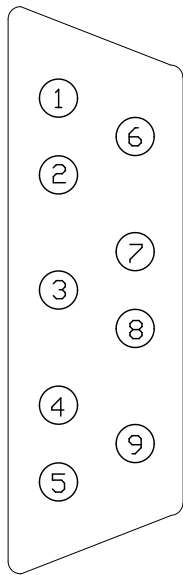

- 1) Loop 1
- 6) Ground/ Earth
- 2) Loop 2
- 7) Ground/ Earth
- 3) Loop 3
- 8) Ground/ Earth
- 4) Loop 4
- 9) Ground/ Earth
- 5) Loop 5

LOOP INPUT NOTE:

Maximum current: 3mA
 High voltage level: +3.3 Volts

LOOP OUTPUT NOTE:

Maximum output current: 200mA
 Maximum external equipment voltage: 50 Volts

CONNECTING LOOP OUT TO A LOGIC INPUT

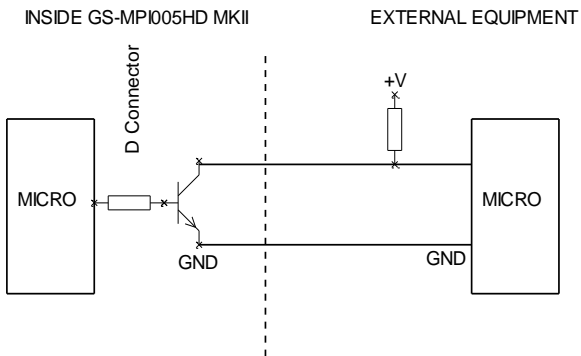

CONNECTING LOOP OUT TO AN OPTO ISOLATOR

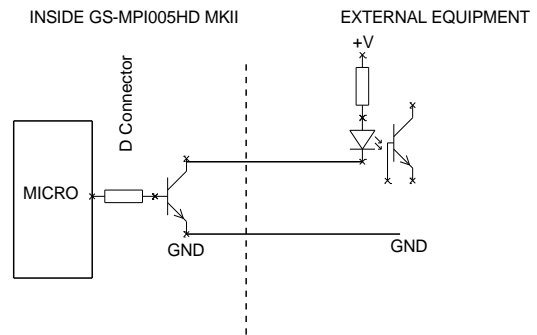

CONNECTING LOOP OUT TO A RELAY

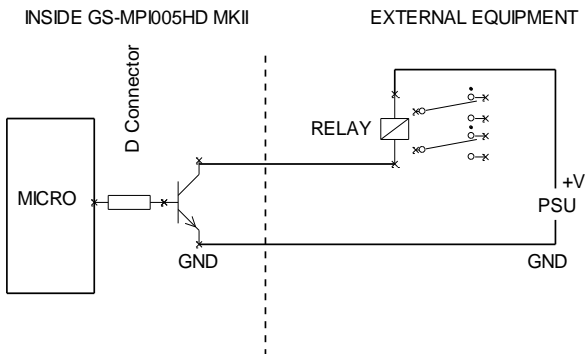

CONNECTING LOOP INPUT

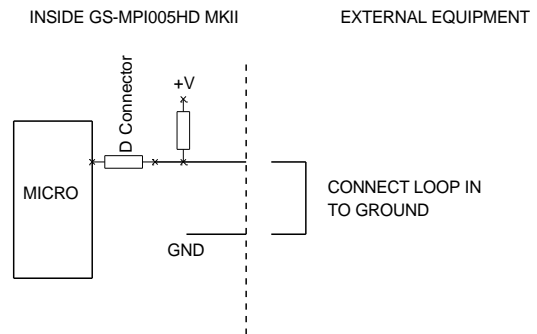

Handset Connector

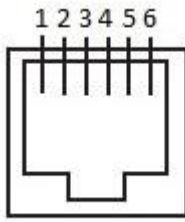

Connector type fitted: 6P6C (Often referred to as RJ11)

Wiring:

Pin 3 = Ring

Pin 4 = Tip