



DNH

HEAD OFFICE, NORWAY
DNH AS

Phone..... + 47 35 98 56 00
Fax..... + 47 35 98 56 10
E-mail..... dnh@dnh.no
Web-site..... www.dnh.no

ENGLAND

DNH WW Ltd

Phone..... + 44 1908 275 000
Fax..... + 44 1908 275 100
E-mail..... dnh@dnh.co.uk

GERMANY

DNH GmbH

Phone... + 49 040 6569 30-0
Fax..... + 49 040 6569 30-30
E-mail..... dnh@dnh.de

USA

DNH Speakers Inc

Phone..... + 1 484 494 5790
Fax..... + 1 484 494 5793
E-mail..... dnh@dnhspeakers.com

SAFE-561-54(T)

ISO 9001 CERTIFIED

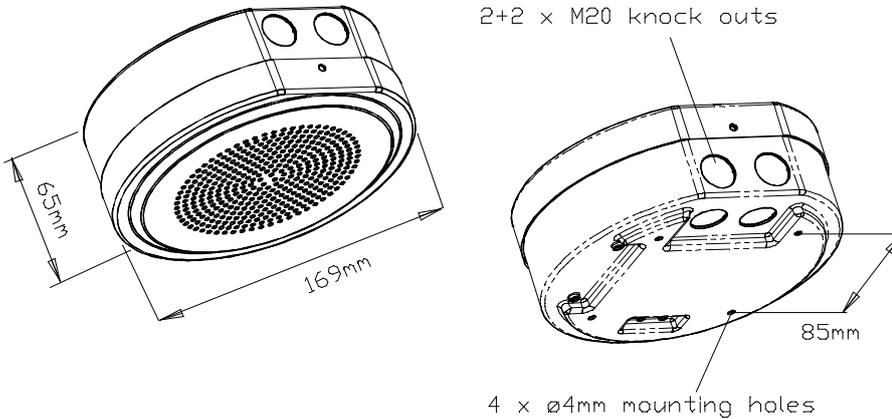

Tested acc. To EN54-24

Type : A

Manufactured by DNH A/S

Kragerø Norway

15 1438-CPR-0204

70/100 volt combined transformer
Primary connections

White : Green	70 V
White : Red	100 V

Secondary
nominal tapings

C : 6,0W	6,0 W	Imp 1500 Ohm
C : 3,0W	3,0 W	Imp 3000 Ohm
C : 1,5W	1,5 W	Imp 6000 Ohm
C : 0,5W	0,5 W	Imp 12000Ohm

Loudspeaker for voice alarm systems for fire detection and fire alarm systems for buildings

Sound pressure levels at 1W/1m P-5/15 PS



Horizontal / vertical coverage angles (±6dB)

1 Oct. Pink noise	500Hz	180°
1 Oct. Pink noise	1KHz	160°
1 Oct. Pink noise	2KHz	105°
1 Oct. Pink noise	4KHz	85°

Specifications acc. testing CNBOP / DNH

Material / Color	Steel /Alu/ Ral 9010
Mounting	4 screws
Termination	Ceramic terminal
Weight w/transformer	1,2 kg
IP-rating	32C
Max. / min. amb. temp	55°C to -10°C / 90°C to -20°C
Rated / max. power	6W
Sensitivity 1W/4m	77 dB
SPL 6W/4m	84 dB
Freq. range	100 Hz – 13000Hz
Measurement environment	Free-field

Sensitivity 100Hz-10KHz 1/3 Oct. Pink noise 1W/4 Meters

100Hz: 38dB	125Hz: 40dB	160Hz: 47dB
200Hz: 50dB	250Hz: 55dB	315Hz: 60dB
400Hz: 64dB	500Hz: 64dB	630Hz: 63dB
800Hz: 63dB	1KHz: 60dB	1250Hz: 62dB
1600Hz:67dB	2KHz: 67dB	2500Hz: 66dB
3150Hz:67dB	4KHz: 67dB	5KHz: 64dB
6300Hz:62 dB	8KHz: 59dB	10KHz: 57dB

SAFE-561-54(T) has been tested in 100 hours max power (6W). The model does not deviate more than ± 3 dB from the original test value. The freq. response curve and impedance complies with the original. All SPL tests are performed in an anechoic chamber (<70m³).

Installation, Operation and Maintenance Procedures

- Mount cabinet to wall/ceiling with four suitable screws. Connect cable to terminal and fasten front part to cabinet with two provided screws.
- For optimum performance, always use the correct voltage / power and operate within the frequency limits as stated.
- Do not open loudspeaker when energized.
- This loudspeaker is supplied with two years warranty against defective workmanship.



1438

DNH reserves the right to alter specifications without notice