



Operating Manual

Electronic Orange

GA904

www.castlegroup.co.uk

Thank you for buying a Castle product, I am sure you will find both the goods and the service to be of the highest quality but if not, then please feel free to write to me personally and I will ensure that your needs are dealt with immediately.

This manual is designed to show you the operation of the goods you have purchased and a very brief insight into acoustics itself. If you would like to become a competent person in the eyes of the law, then you may like to know more about our Competent Persons training course for Noise at Work Regulations. You can visit www.castle-training.com to find out more.

It is my intention for Castle Group Ltd to provide a wide range of technical health and safety products and Services of the highest standard. If you would like to know more about any of our other products and services then please telephone on +44(0)1723 584250 or visit www.castlegroup.co.uk

A handwritten signature in black ink, appearing to read 'S Bull', with a stylized flourish at the end.

Simon Bull
Managing Director

Copyright

This manual is copyrighted with all rights reserved. Copying in part or in whole is prohibited without the prior written consent of Castle Group Ltd.

Precautions

- Only operate the instrument as described in this manual.
- These are precision instruments, protect from shocks and vibrations.
- Ambient conditions for the operation of the unit are as follows:-
 - Temperature: -10°C to +50°C
 - Relative Humidity: 30 to 90%
- Protect the unit from extremes of temperature and humidity, direct sunlight and air with a high salt or sulphur content.
- Do not use any solvents or cleaning agents on the instrument. Use only a soft dry cloth or a soft cloth lightly moistened with water when necessary.
- Do not allow any conductive objects, such as wire or metal particles to enter the unit.
- Do not try to disassemble the instrument or attempt any repairs as this will invalidate your warranty. Take a note of the condition of the instrument and contact your authorised Castle service station.
- To ensure continued precision performance of your instrument have it checked and serviced at regular intervals.

Contacting Castle Group

This manual contains complete operating instructions for the Noise Activated Warning Sign, read it carefully and you will quickly become familiar with your instrument and its operation.

If you do encounter problems with the operation of your instrument please feel free to contact customer support with your enquiry on: -

Telephone:	+44 (0)1723 584250
Fax:	+44 (0)1723 583728
Website:	www.castlegroup.co.uk
Email:	techsupport@castlegroup.co.uk sales@castlegroup.co.uk

Contents

Introduction	1
Instrument Description	1
Installation	2
Power Rating Limitations.....	2
Items Supplied.....	3
Additional Items Required	3
Mounting the GA904	3
Mounting the Orange Beacon Warning Light.....	4
Mounting the Microphone.....	4
Microphone Wiring.....	4
Wiring to the Orange Beacon	5
Auxiliary Contact Wiring.....	5
Power Wiring to the GA904.....	5
AC, DC, Power Output Wiring.....	6
Controls	7
Operating Modes	7
Displays	8
Calibration and Set-UP	8
Calibration (RV1).....	8
Trip Time (RV2)	8
A and B Frequency Weighting (SW2)	9
Trip Level (SW3)	9
Warning Level (SW4).....	9
PCB Identification	11
Technical Specification	12
Accessories	13
Warranty and After Sales Service	14
Instrument Details	14
Instrument Disposal	15
Disclaimer	15

Introduction

The GA904 Electronic Orange is a system for use where amplified sound could give rise to complaints about noise from neighbours. If the sound level should exceed the trip level the unit will remove power from the stage or amplifier system. The orange beacon warning light gives an indication of the noise level to enable the stage manager or the person in control of the amplifier output to regulate the sound level below the maximum permitted.

A problem associated with amplified sound is the possible environmental effects outside the premises and the annoyance and nuisance caused to adjoining residential premises. In this case external levels are related not only to the internal levels but also the degree of insulation offered by the structure of the premises.

This can only be changed by costly and often prohibitive changes to the building. However, it is clear that for any given structure, control of the internal sound levels will affect the external levels.

In many cases these external levels may well be the determining factor for levels inside the building and for this reason the GA904 was designed. Castle Group invented the first "Electronic Orange" Entertainment Noise Controller in 1971, since then it has become an industry standard, recommended by many Local Authority Environmental Health Officers.

The GA904 has been developed from the original "Noise Limiter" and now offers even more control.

Instrument Description

The sound in the entertainment venue is detected by an independent microphone installed in the body of the room in such a way that the sound detected is predominantly that of the amplifier system output.

Once installed, the microphone signal is received at the control box of the GA904 and processed by a sound measurement system. If the pre-set trip level is approached a warning is given, set by the warning level control, to allow the operator to turn the volume down. If the trip level is exceeded the trip timer will switch power off the amplification equipment for a pre-set time. After this pre-set time the power will always be restored regardless of the sound level unless you are using the manual reset function (see page 10).

The unit itself has a built in 20 second mute function to ensure this. When the mute time has expired, the unit will resume measuring the sound level and the power will be cut if it is not turned down. The process would repeat if the volume is not turned down. The reason for the mute function is to allow the operator of the amplifiers or discotheque time to respond by manually turning

down the amplifier output and to ignore any momentary increase in level caused by the patrons when the power to the amplifiers has been removed.

However, the function of the “Electronic Orange” is not so much to interrupt entertainment as to provide adequate notice of excessive levels in order that they may be controlled to below the required maximum. The warning beacon gives up to 12dB warning that the trip level is being approached.

Other features include a three colour LED bar graph display showing SPL [sound power level] which makes monitoring the level easy; a choice of standard “A” weighting or “B” weighting characteristics which is more effective for bass control. Outputs are available for remote analogue or digital displays. In addition to the standard measurement microphone input the facility is provided for an external trigger input from, for example, a contact on a fire door. In addition, the device is fitted with an anti-tamper circuit and the cause of a cut-off is clearly indicated by the “Level”, “Microphone”, and “External” indicators.

Installation

WARNING:

THE GA904 SHOULD BE WIRED TO THE MAINS POWER SUPPLY BY A QUALIFIED ELECTRICAL INSTALLATION ENGINEER.

MAINS VOLTAGES ARE PRESENT IN THIS UNIT.

The warning above applies to any work carried out on the main body of the GA904 unit, as live terminals are exposed inside the box.

The only exception to this rule is the area inside the hinged door on the left of the instrument, which is provided to allow the appropriate authority to make any adjustments to the trip time and level which are found necessary. There are no mains voltages present in this section of the GA904 enabling the unit to be set up in safety. For more information see Section 4.

Power Rating Limitations

The maximum rating of the GA904 control box is 30 Amps. This is limited by the current switching capacity of the relay inside the unit. Hence the unit can switch a mains ring fused at 30 Amps.

However the maximum current is also limited by the cable running to and from the control box, hence the mains input must incorporate a fuse no greater than the current carrying capacity of the cables.

WARNING:

MAXIMUM CURRENT 30 AMPS OR THE RATING OF THE MAINS CABLE, WHICHEVER IS THE LOWEST.

The maximum power rating can be increased by using an external contactor controlled from the GA904. In this case the maximum power rating will be the contactor power rating.

Items Supplied

The following components are supplied with GA904:

- a) Control box – White box marked GA904.
- b) Orange beacon warning light.
- c) Microphone complete with 10 metres of cable to connect to the control box.
- d) Two plastic seals for security (fixed to hinged door when the instrument is calibrated).
- e) 2 keys for the Manual/Auto/Override switch. *(NB Two keys are supplied by Castle Group Ltd with each switch. Duplicates are not kept by or available from Castle Group Ltd.)*
- f) Microphone mounting clip.
- g) Padlock (for added security). *(NB Two keys are supplied by Castle Group Ltd with each padlock. Duplicates are not kept by or available from Castle Group Ltd.)*

Additional Items Required

- a) Mains cable to divert the power supply to the control box and from the control box to the stage.
- b) Light duty twin cable (12 volt/200mA for the signal to the beacon)

Mounting the GA904

The white control box can be mounted at any convenient point using screws in the holes provided. See figure 3.1.

It should be borne in mind that:

- a) The microphone cable run to the control box should be as short as possible.
- b) Reduce expensive mains power cable runs by inserting the control box with the shortest possible diversion of stage power.

c) The control box should be visible to person operating it so that any trip condition can be easily reset.

d) Occasionally performers or the audience may be tempted to vandalise the equipment if the performer refuses to turn his volume down and the unit keeps tripping. The unit should not be too readily available to the audience.

Mounting the Orange Beacon Warning Light

This may be mounted at any convenient point where it may be seen by the audience and the person in control of amplifier volume. This is 12 Volt D.C. and no difficulties have been experienced with cable of up to 50 metres.

Mounting the Microphone

The microphone should be mounted in the body of the room out of tampering fingers and directed towards the main source of the sound. Special care should be taken to avoid audience pick-up, as a premature or undesirable cut-off could be caused by mounting (for example) over a club bar where shouting customers or applause could be unrepresentative of the overall sound level in the room. The microphone should be mounted on a vibration free mounting such as the microphone mounting clip supplied.

Microphone Wiring

The microphone lead connects directly to the microphone using the connector provided. This connector is a switch craft type A3-M with the following connections.

Pins 1 – screen

Pin 2 – signal (blue or white)

Pin 3 – pre-amp power (red or black) 12 volt

The other end of the cable must be connected to the terminal block on the PCB as shown below:

J11/1 – Screen

J11/2 – Signal (blue or white)

J11/3 – Preamp power (red or brown) +12 volt

The microphone cable should be inserted through the far left slot in the lower bottom of the case. A cable grip is provided which should be placed around the cable approximately 150mm (6 inches) from the bare ends of the cable. This should then be pushed home through the slot to hold the cable tight and prevent it from pulling out. It may be necessary to compress the cable grip using a pair of pliers to insert it through the slot.

While the 10 metre cable provided is adequate for most installations, longer cables are available to order, or screened twin cable may be used on the connector supplied, up to a maximum of 30 meters.

In long cable runs, take special care to separate the microphone signal cable from electric power cables, especially those to fluorescent light fittings.

Wiring to the Orange Beacon

The Orange beacon warning light should be connected to the GA904 main body using 2-core cable rated at 1A. The connections are:

J9/1

J9/2

Auxiliary Contact Wiring

A normally closed door contact may be wired to the GA904 such that if the door is opened the GA904 will trip.

The connections are:

J8/1

J8/2

Note that the unit is supplied with a shorting link between these connections. The link must be kept in place if the door contact feature is not used. The link should be removed if a door switch is used.

Power Wiring to the GA904

No additional items are required if the control box can be conveniently wired into the mains circuits(s) which supply all the amplifiers in use. The simplest installation is made by taking power from a wall socket which normally supplies the amplifiers. Where possible the unit should be fed from a switched junction box, fused at the current capacity of the cable, and the output of the GA904 then taken to all the available sockets on the stage. In this way any visiting discotheque or group can only use the controlled sockets.

The GA904 should be wired to the main power supply by a qualified installation engineer. See earlier warning. The power cable should be fed in through the far right hand gland nut and screwed firmly to the right hand connector block.

Controlled power output to the stage is taken from the left hand connector block and fed through a gland to the left of the power input. See figure 3.1.

AC, DC, Power Output Wiring

These signals are available for connecting chart recorders, tape recorders, or external displays etc. The connections are as follows:

J10/1	-12
J10/2	0V
J10/3	+12V
J10/4	AC Output
J10/5	DC Output
J10/6	2.5V Reference Voltage

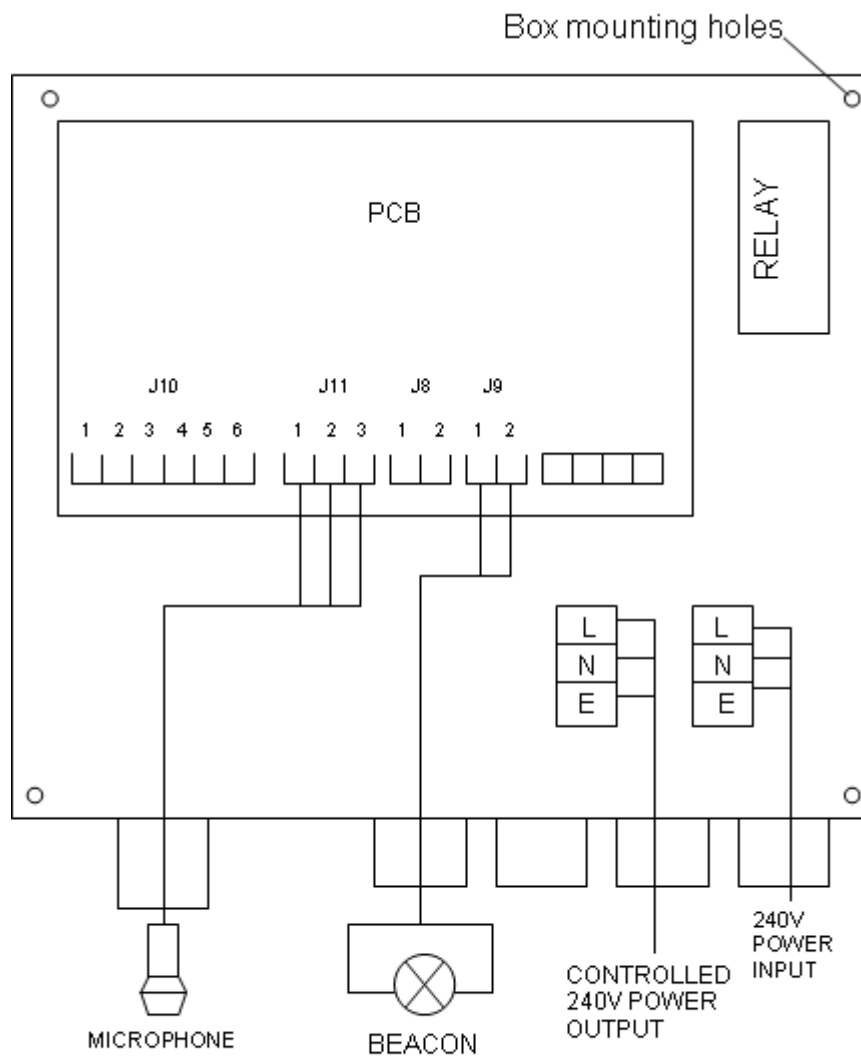

Figure 3.1 WIRING SCHEMATIC

Controls

When the instrument has been installed it requires virtually no control and is by nature automatic. However please read the following notes on the three modes of operation and the various displays provided for ease of use.

Operating Modes

There are three main modes of operation key selected as shown below:

NOTE: The instrument is supplied with two keys. These keys are individual to your instrument. Please make copies in case these keys are misplaced. Castle Group does not keep spare keys and cannot supply replacements.

Manual

When the level has exceeded the trip level indicated by the top red LED on the multi-level display, then the unit will trip. This will be indicated by the power being removed and a red “tripped” light. In the manual position power must be restored by pressing the reset button, which is prompted by the reset LED being illuminated.

Auto

When the unit has tripped as above, the power will be restored automatically after a pre-set delay. This delay time is user adjustable between 1 to 10 seconds. When the power is restored a mute function prevents the unit from a further trip for 20 seconds from the beginning of the trip period. This mute or disabling of the microphone input is necessary to allow the operator of the amplifiers a reasonable time to adjust the level and ignore any momentary increase when power.

This is normally the preferred mode of operation.

Override

In this mode power output is maintained even during a trip condition. This should only be used when it is no longer necessary to control the level of sound in the hall and surrounding buildings. The GA904 unit would not normally be left in this position, but it may be useful if the situation with annoyance to neighbours changes and is no longer a problem. Also a bypass function may be useful when other equipment is being installed, tested or repaired.

All the above modes are controlled by the keyswitch on the front panel and it is suggested that the unit normally be left in the “auto” mode and the key retained safely by the building manager and not left for any unauthorised person to tamper with the function of the equipment.

Displays

The GA904 features several indicators to show the current operational state of the unit and why it has tripped. These include:

A multi-level LED display bar showing the sound pressure level (Lp) relative to the trip level, which is shown by the top red LED. This is indicated in 3 dB steps, in three colours, red, yellow, and green. Therefore it is easy to see if the level is in the trip, warning or safe area of operation.

When a trip has occurred, shown by a red “tripped” LED, the cause will be indicated by three LEDs. These are “Level”, if the sound level is too loud, “Mic” if the anti-tamper sensor on the microphone cable shows it has been disconnected and “Ext” if an external trigger input has tripped the unit.

The most important indication is given by the orange coloured remote beacon which is why the entertainment noise controllers became known as the “Electronic Orange”. The beacon will warn the operators when the trip level is approached.

Calibration and Set-Up

Although the GA904 will have been calibrated at the factory before despatch it may need slight adjustment on site due to the positioning of the microphone and the acoustics of the venue. It may also be necessary to alter the settings of the unit due to a change of requirements. On the GA904 it is easy to change between different trip and warning levels without altering the absolute calibration of the unit. This is achieved by three sets of PCB mounted switches.

However, it is recommended that the unit is left on its original settings and only altered if it is advised by an acoustic consultant or local environmental health officer. Figure 5.2 shows the location of all printed circuit board adjustments.

Calibration, RV1

This potentiometer gives +/- 5dB adjustment to the calibration level and is factory set to match the microphone supplied. *This control should not be adjusted.*

Trip Time, RV2

This potentiometer may be adjusted to control the trip period from 1 second to 10 seconds.

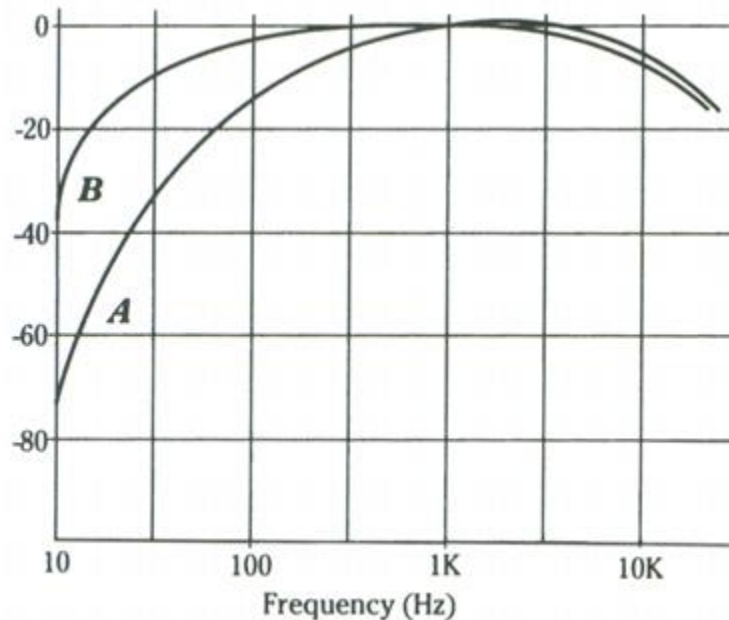

Figure 5.1 'A' AND 'B' FREQUENCY WEIGHTING

A and B Frequency Weighting, SW2

This is a two way switch which selects the required frequency weighting. The switch must be switched right for "A" weighting and left for "B" weighting. Figure 5.1 shows the "A" and "B" frequency weighting characteristics.

Trip Level, SW3

This switch is used to set the trip level from 75dB to 112.5dB in 2.5dB increments.

Warning Level, SW4

This switch is a four way slide switch selects when the warning beacon will switch on. The level is relative to the trip level and may give a warning -3, -6, -9, or -12dB down from the trip level.

The following tables show the switch position against trip level, and warning levels.

Trip Level	Switch SW1			
dB	1 20dB	2 10dB	3 5dB	4 2.5dB
75	X	X	X	X
77.5	X	X	X	O
80	X	X	O	X
82.5	X	X	O	O
85	X	O	X	X
87.5	X	O	X	O
90	X	O	O	X
92.5	X	O	O	O
95*	O	X	X	X
97.5	O	X	X	O
100	O	X	O	X
102.5	O	X	O	O
105	O	O	X	X
107.5	O	O	X	O
110	O	O	O	X
112.5	O	O	O	O

O = Open (Up) X = Closed (Down) *Factory Set

Warning Level dB (WRT Trip Level)	Switch Position SW4
-12	1
-9	2
-6	3*
-3	6

PCB Identification

The diagram below shows the position of the following components on the PCB.

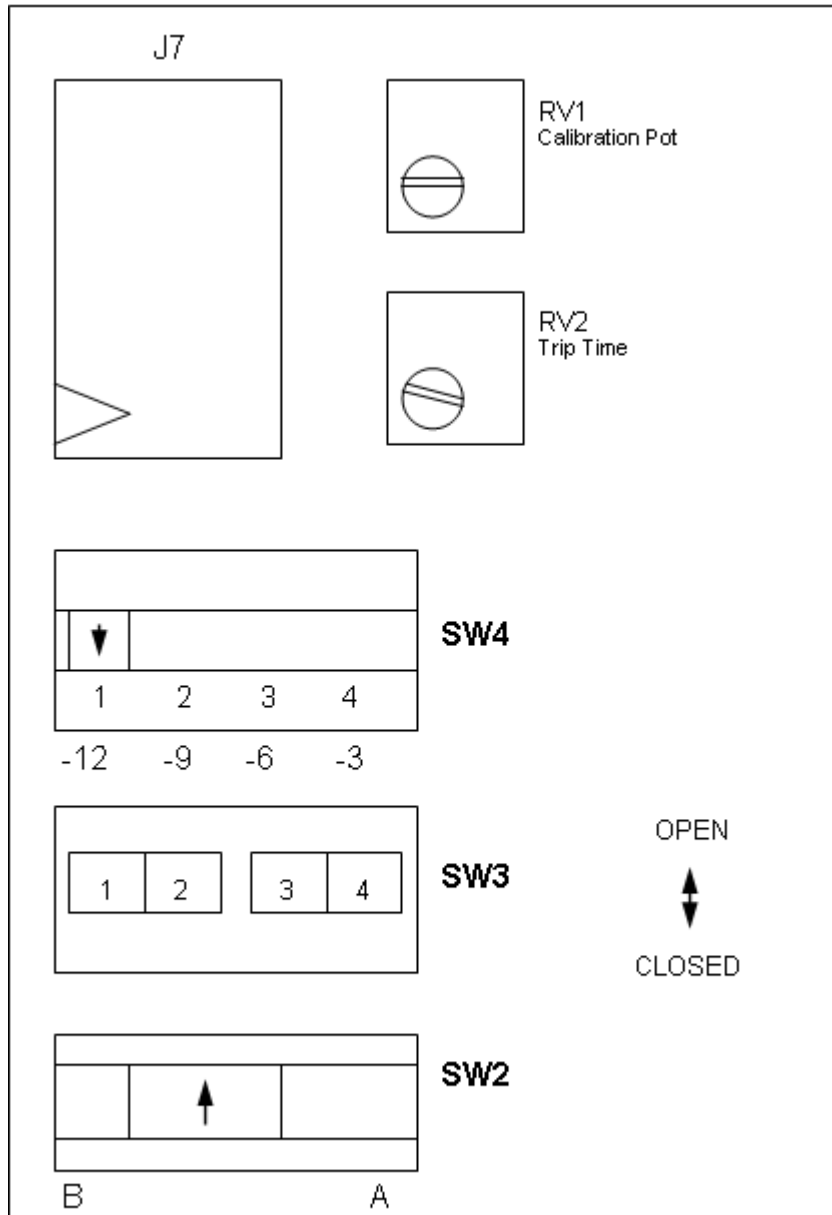

Figure 5.2 CALIBRATION ADJUSTMENTS

Technical Specification

TRIP RANGE

75dB to 112.5dB in 2.5dB steps switch selectable
+/- 5dB calibration control (factory set)

WARNING RANGE

-3, -6, -9, -12dB down on trip level select switch

TRIP TIME

1 second to 10 seconds user adjustable (potentiometer)

MUTE TIME

20 seconds from beginning of trip time

POWER SWITCHING

The GA904 will switch a 240V 30A load

OPERATING MODE

Manual: When tripped unit must be manually reset

Auto: When tripped unit automatically resets after trip time

Override: Power output is maintained even during trip condition

Manual, Auto, Override are keyswitch selectable

FREQUENCY WEIGHTING

A and B

TIME WEIGHTING

Slow 1000ms

DISPLAYS

Analogue bar graph display showing sound pressure level

Trip indication with trip source

Warning indication

Manual reset prompt

In the interest of continued development, Castle Group Ltd reserve the right to change any specification without due notice.

Accessories

The following are a list of available accessories and spare parts which can be ordered from Castle Group Ltd.

01ZL1011-10	10m Microphone Cable
01ZL1011-20	20m Microphone Cable
01ZL1011-30	30m Microphone Cable
01MK376PXL	Microphone assembly for GA904
70MIS01730	Microphone Stand
01MC1	Microphone Clip
70MIS01510	Plastic Seals
70MIS00280	12V Bulbs for Beacon
67CON01410	Connector Strain Relief Bush
01PADLOCK	Padlock for GA904
68SWI00700	3 Position Key Switch

Warranty and After Sales Service

Castle Group Ltd design and manufacture precision instruments, which if treated with reasonable care and attention should provide many years of trouble free service. In the event of a fault occurring, during the warranty period, the instrument should be returned to Castle Group Ltd, in its original packaging, or to an authorised agent. Please enclose a clear description of the fault or symptom.

Details of the warranty cover are available from Castle Group Ltd or an authorised agent.

All instruments are designed to meet rigid British and International Standards. An annual calibration is recommended to ensure that these high standards are maintained. This is particularly important for cases in which instrument readings are to be used in litigation or compliance work.

For warranty and service return to: -

The Service Department
Castle Group Ltd
Salter Road
Cayton Low Road Industrial Estate
Scarborough
North Yorkshire
YO11 3UZ

Telephone: +44 (0)1723 584250
Fax: +44 (0)1723 583728
Email: techsupport@castlegroup.co.uk
Web: www.castlegroup.co.uk

Any misuse or unauthorised repairs will invalidate the warranty.

Instrument Details

For your records and for future correspondence with Castle Group Ltd regarding your instrument, please complete the following details: -

Instrument Model

Instrument Serial Number

Purchase Date

Instrument Disposal



The symbol shown here can be found on your instrument and means that the product is classed as electrical or electronic equipment and should be disposed of at the end of its life separately to your commercial or household waste.

The Waste of Electrical and Electronic Equipment Directive (2002/96/EC) has been established to help reduce the influx on landfill sites and effectively treat hazardous substances by using best practices for the recovery and recycling of products.

There are various collection systems in place within the EU for the disposal of your product. To find the nearest UK waste recycling point in your area, enter your postcode in the website www.recycle-more.co.uk

For more information please contact your local authority, the dealer where you purchased your product or Castle Group Ltd.

Disclaimer

Whilst every effort is made to ensure the accuracy and reliability of both the instrument described and the associated documentation, Castle Group Ltd makes no representation or warranties as to the completeness or accuracy of this information.

Castle Group Ltd assumes no responsibility or liability for any injury, loss or damage incurred as a result of misinterpreted or inaccurate information.

Any documentation supplied with your product is subject to change without notice.