

Amphenol EP Male Cable Connector Assembly

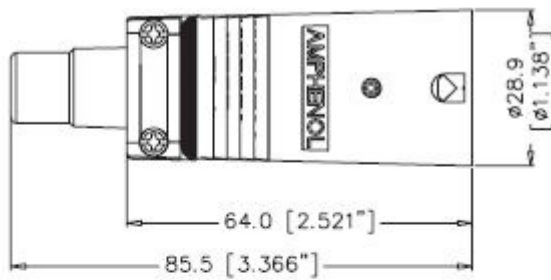

EP Male cable connector,
Machined contacts,
Metal Shell

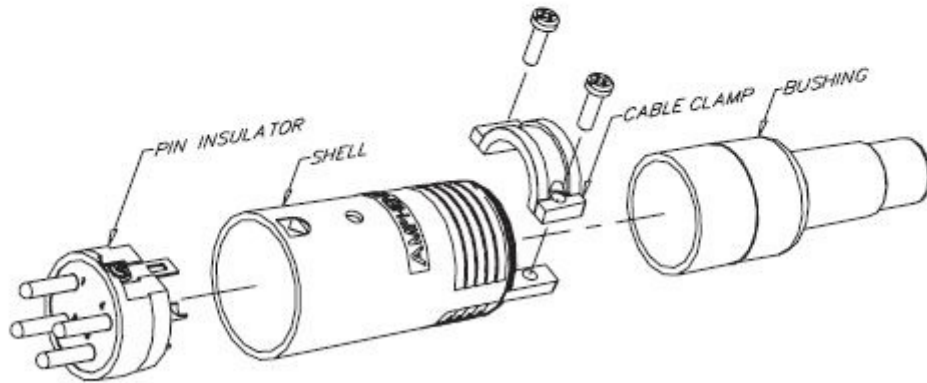

Step One: Feed shell then the bushing over cable, (cable absent for clarity).



Step Two: Feed bushing through the shell, (cable absent for clarity).

Amphenol EP Male Cable Connector Assembly



Step Three: Terminate cable to pins and feed into shell with screw aligned to the hole on the shell, (cable absent for clarity).



Step Four: Pin insert located correctly when screw is visible through hole, (cable absent for clarity).

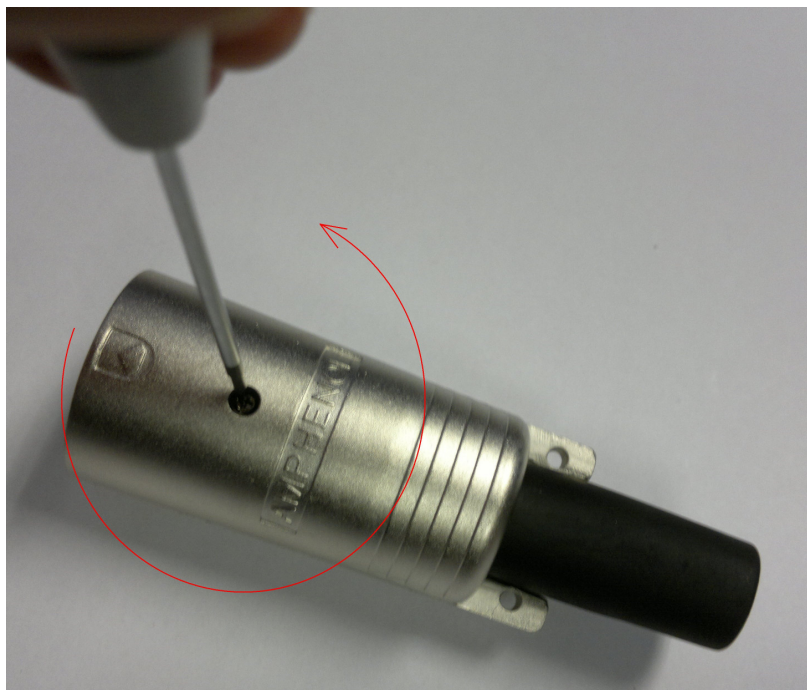

Step Four: Using small screwdriver rotate screw anti-clockwise until screw binds with shell, (cable absent for clarity).

Amphenol EP Male Cable Connector Assembly



Step Five: Screw located correctly, (cable absent for clarity).



Step Six: Secure cable with clamp assembly, (cable absent for clarity).

- 44-411 - AMPHENOL EP4-11 4 pin female cable
- 44-412 - AMPHENOL EP4-12 4 pin male cable
- 44-511 - AMPHENOL EP5-11 5 pin female cable
- 44-512 - AMPHENOL EP5-12 5 pin male cable
- 44-611 - AMPHENOL EP6-11 6 pin female cable
- 44-612 - AMPHENOL EP6-12 6 pin male cable
- 44-811 - AMPHENOL EP8-11 8 pin female cable
- 44-812 - AMPHENOL EP8-12 8 pin male cable